

# **CL Challenger Lifts**

## **Installation, Operation & Maintenance Manual** ***Wheel Lift System***

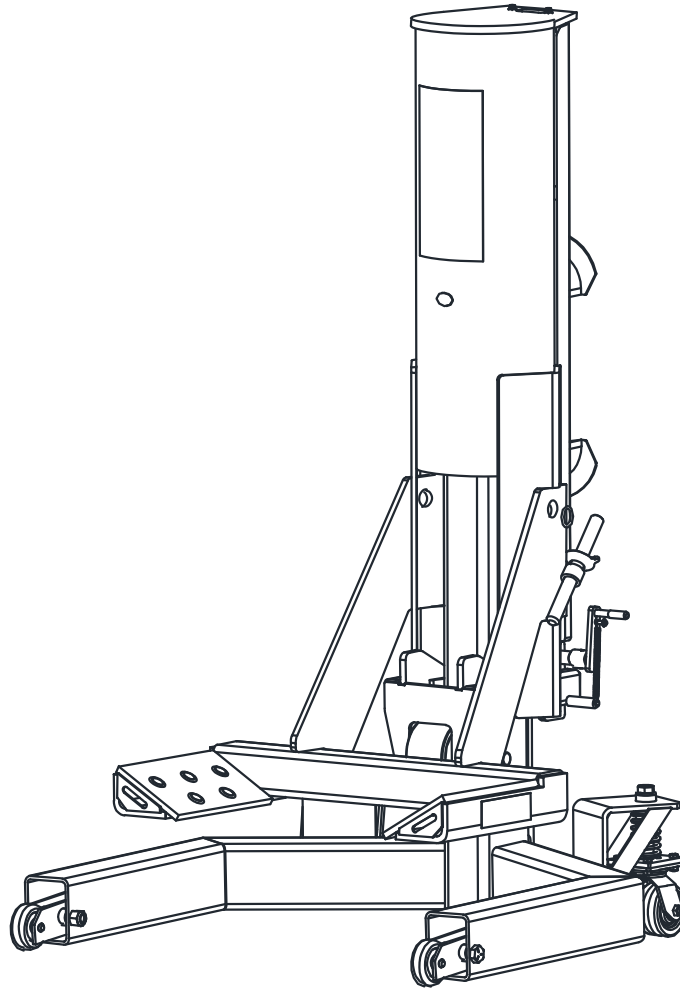

### **MODEL**

## **CLHM-MR20 AND CLHM-MR30**

**10,000 LBS./ 15,000LBS. CAPACITY PER LIFT**  
**20,000LBS./ 30,000 LBS. LIFT SYSTEM CAPACITY**

2311 South Park Rd Louisville, Kentucky 40219

Email: [sales@challengerlifts.com](mailto:sales@challengerlifts.com) Web site: [www.challengerlifts.com](http://www.challengerlifts.com)

**Office 800-648-5438 / 502-625-0700 Fax 502-587-1933**

**IMPORTANT: READ THIS MANUAL COMPLETELY BEFORE  
INSTALLING or OPERATING LIFT**

## GENERAL SPECIFICATIONS

	<b>CLHM MR20</b>	<b>CLHM MR30</b>
Maximum Capacity, each lift	<b>10,000 lbs</b>	<b>15,000 lbs</b>
Maximum Capacity, system	<b>20,000 lbs</b>	<b>30,000 lbs</b>
Maximum Air Pressure	<b>160 psi</b>	
Minimum Wheel Dia w/o Adapters	19"	
Minimum Wheel Dia with Adapters	16"	
Maximum Tire to Fender Clearance	8"	
System Weight	1,192 lbs	1,496 lbs
Weight per Lift	594 lbs	746 lbs
Adapter Weight	22 lbs	
Width	42 1/4"	
Depth	43 1/4"	44"
Height (lowered)	58 3/4"	59"
Height (raised)	88 1/2"	89"

# Receiving Inspection

Before attempting to operate this system, thoroughly read and understand this manual. Inspect the jacks immediately upon delivery. If shipping damage is evident, inform the delivering carrier immediately and contact the manufacturer using the contact information on the back cover of this manual.

## Introduction

### Owner and / or Operator Responsibilities

The owner and / or user must have an understanding of the manufacturer's operating instructions and warnings before using this system. The use of portable lifting devices is subject to certain hazards that cannot be avoided by mechanical means, but only by the exercise of intelligence, care, and common sense. Personnel involved in the use and operation of equipment shall be careful, competent, trained, and qualified in the safe operation of the equipment and its proper use when servicing motor vehicles and their components. Examples of hazards are dropping, tipping, or slipping of vehicles or their components caused primarily by improperly securing loads, overloading, off-centered loads, use on other than hard level surfaces, and using equipment for a purpose for which it was not designed. Warning information should be emphasized and understood.

The owner / manager must make this manual available to all personnel using this jack at your direction. They must read and understand the contents of this manual. If the operator is not fluent in English, the manufacturer's instructions and warnings shall be read to and discussed with the operator in the operator's native language by the purchaser / owner, making sure that the operator comprehends its contents and observes the proper procedures for use of this jack.

Owner and / or user must study and maintain for future reference the manufacturer's instructions. Owner and / or user are responsible for keeping all warning labels and instruction manuals legible and intact. Replacement labels and literature are available from the manufacturer.

Model MR20 AND MR30  
Installation, Operation and Maintenance

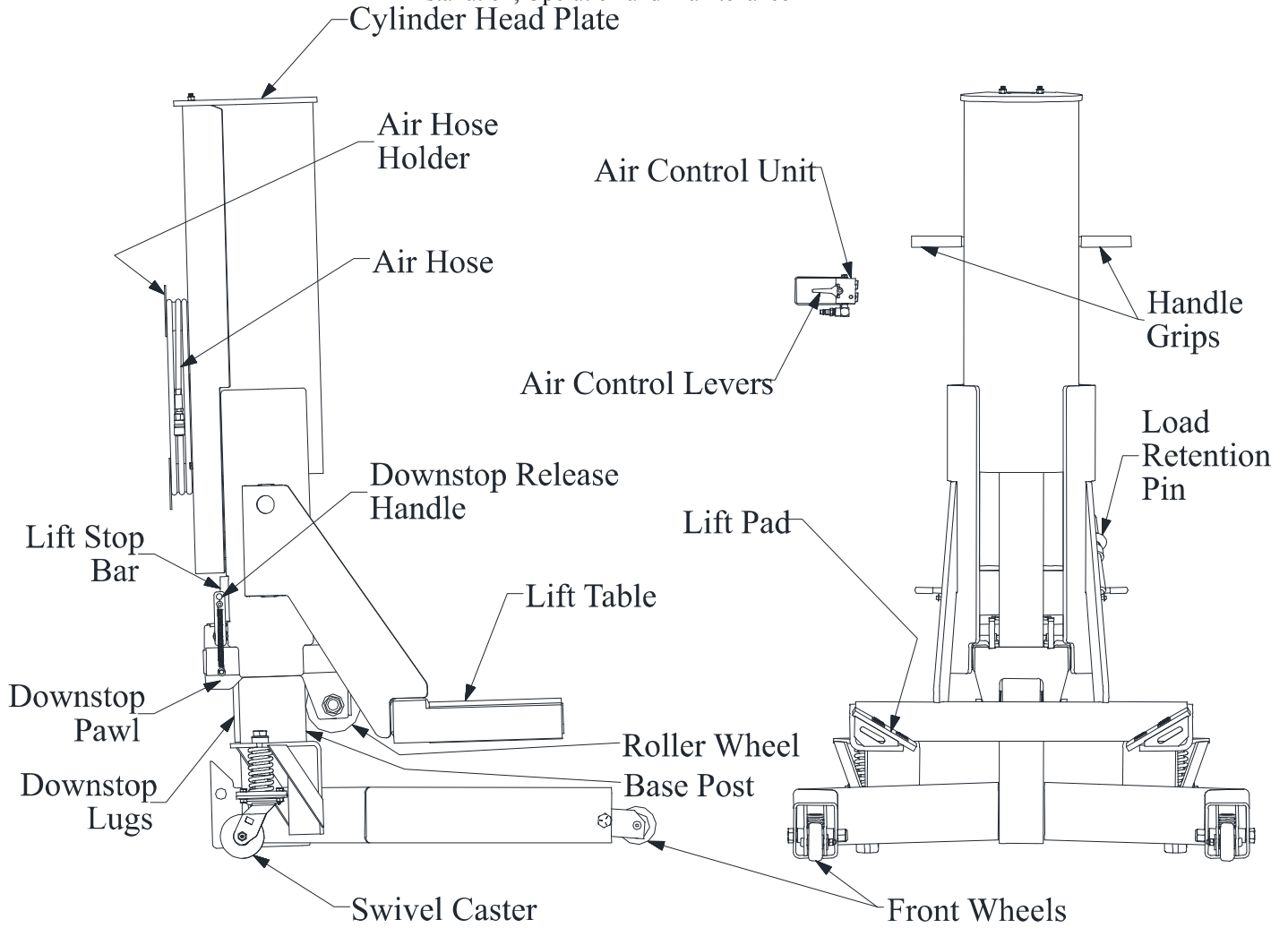

Location of the Load Retention Pin varies by model.

## Safety Instructions

# **WARNING**

To avoid serious injury or death, read this manual carefully before operating this system. Contact the manufacturer using the contact information on the back cover of this manual if you have any questions. Failure to understand and obey safety instructions may result in unsafe or improper use of this product.

1. Maximum capacity for the unit is printed on a tag located on top of one of the caster brackets. Never use the lift system to raise or support more than maximum capacity per lift. Never use a lift as a stand to support more than maximum capacity per lift.
2. No alterations shall be made to this product.
3. Use the lift system only on hard, level surfaces capable of sustaining the load.
4. The lift system is designed to lift over-the-road vehicles with rims of at least 19 inches in diameter (16 inches in diameter if the manufacturer supplied optional adapters are used). *NEVER* use the lift system on vehicles with rims *less* than 19 inches in diameter (16 inches if adapters are used).
5. Use the lifts only in pairs, on the opposite ends of the same axle.
6. *NEVER* use the lift system to raise a vehicle by the frame or structural member. The lift is designed to be used only beneath the vehicle tires.
7. *NEVER* raise one end of a vehicle if the opposite end is supported by stands.
8. To prevent tipping, never raise or lower just one side of a vehicle.

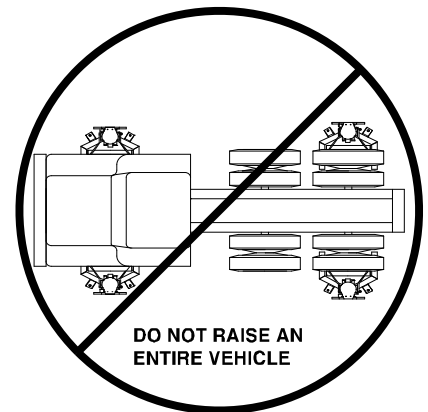
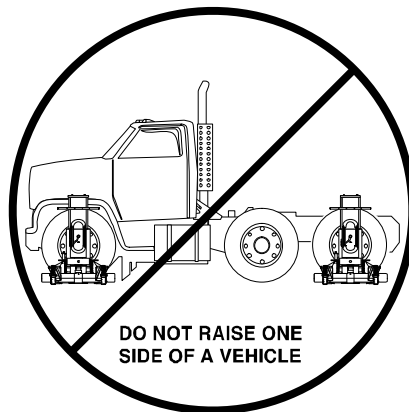
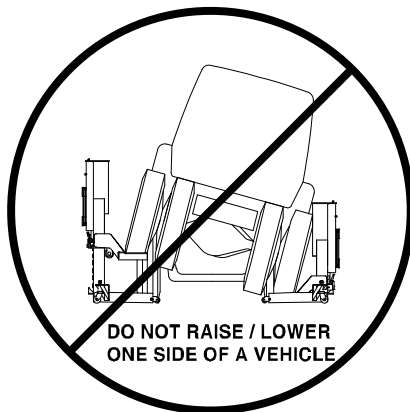

9. *NEVER* lift an entire vehicle with the lift system.
10. Do not allow any part of your body under the vehicle until both the lifts are pinned as stands.
11. *NEVER* use the lift system in conjunction with any other equipment used to raise a vehicle.
12. *NEVER* use blocks, adapters not supplied by manufacturer, or cribbing devices with this lift system.
13. *NEVER* use the lift system as a wheel dolly for the removal of tires.
14. *NEVER* allow the lift system to be used unless all warning labels and instructional decals are in place and legible.
15. *NEVER* use this jack to lower a vehicle if the vehicle was raised using another lifting device or devices. The vehicle should be lowered with the same equipment that was used to properly raise it (read and follow the warnings and instructions for this other equipment).

Failure to understand and obey this warning may result in personal injury or death.

## Optional Adapters

### **WARNING**

To prevent serious injury or death from a falling vehicle, use MR-Adapters only for vehicles with rims between 16" and 19" in diameter.

### **CAUTION**

Install the MR-Adapters with both hooks in the holes of the lift pad. Proper installation is shown in figure 1.

Make sure the wheel rims on the vehicle to be raised are a minimum of 19" in diameter, unless you are using the manufacturer supplied MR-Adapters with the lift system. With the adapters, properly positioned on the lift pads, vehicles with wheel rims of 16" can be safely raised. For rims of 16-19 inches in diameter, install the MR-Adapters as follows:

### Installing the MR-Adapters

To install the MR-Adapters, insert the adapter hooks on each MR-Adapter into the top two holes on each of the four lift pads. See top view and front view figures below.

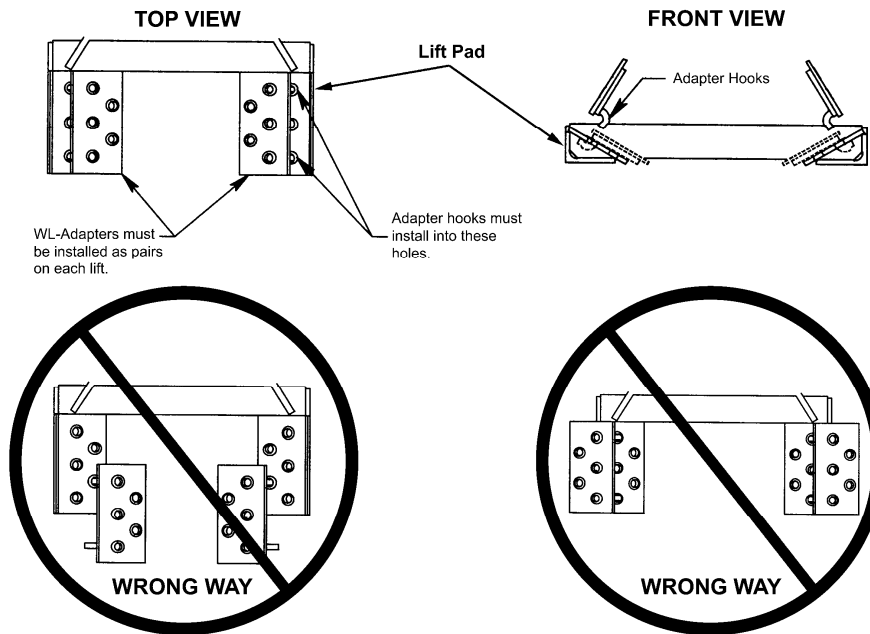
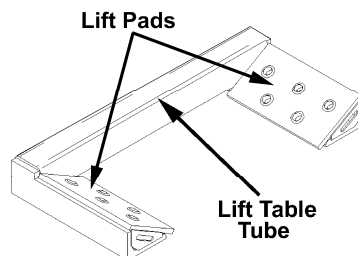

**Figure 1**

*Installing MR-Adapters.*

### Using the MR-Adapters

1. Use the MR-Adapters only on vehicles with rims of 16 inches - 19 inches in diameter. Follow normal operating instructions to use the Lift system with MR-Adapters installed.



## Operating Instructions Preparing the Lifts and Vehicle

Figure 2

Lift table tube identification.

### **WARNING**

To prevent serious injury or death from a falling vehicle, make sure the vehicle's rims are at least 19 inches in diameter (or 16" and 19" if MR-Adapters are used). Make sure the tires are properly inflated, to maintain necessary tire diameter. Make sure weight on the vehicle axle does not exceed the total capacity of the lift system or allow an individual lift to be overloaded.

### **WARNING**

To prevent serious injury or death from a falling vehicle, make sure that the hoses avoid all pinch points and that they do not pass under the base of a lift. The base lowers slightly as the vehicle is raised.

1. Before proceeding, review the Safety Instructions section of this manual.
2. Position the vehicle on a hard, level surface and set the parking brake.
3. Check that the tires on the vehicle are properly inflated, to maintain necessary tire diameter.
4. Position the Wheel Lifts so the lift pads are cradling the tires at opposite ends of the same axle.
5. Push the lift pad under the tire until the lift table tube contacts the tire (see Figure 2 for identification).
6. Release the vehicle's parking or air brake and place the transmission in neutral.
7. Uncoil the air hoses from both lifts and route them for connecting to the air control unit, at either the front or the rear of the vehicle.
8. Position yourself at the front or rear of the vehicle so both lifts are visible. Face the vehicle and hold the air control unit with the air control levers pointing toward the vehicle and the quick couplers on the underside of the air control unit. (See figure 3 for orientation).
9. Connect the air hose from the lift on your right to the right side of the air control unit. Connect the air hose from the lift on your left to the left side of the air control unit (see Figure 3 for connections).
10. Connect the air supply (145 psi max) to the air inlet port of the air control unit (see Figure 3 for connection).

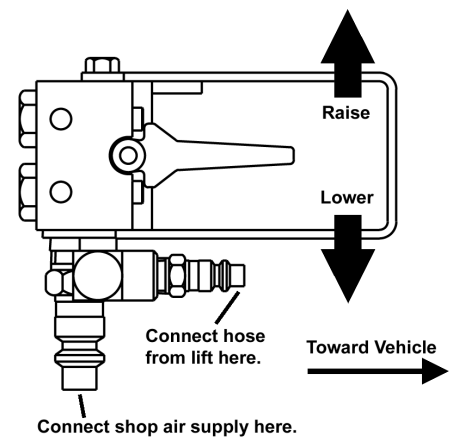

Figure 3

Move lever UP to raise lift, DOWN to lower. Operate BOTH levers SIMULTANEOUSLY to prevent vehicle tipping.

## Raising A Vehicle

# **WARNING**

To prevent serious injury or death from a falling vehicle, operate *both* air control levers *at the same time* and keep the vehicle level as it is raised or lowered.

1. Raise the vehicle by lifting up on both the air control levers at the same time. Be sure to operate the air control levers so the vehicle stays level at all times as it is raised or lowered.
2. Raise the vehicle until it is 2"- 4" above the desired working height (the vehicle will lower by that amount as the downstop lugs engage). Visually confirm that the downstop pawls will engage downstop lugs at the same height on each lift. If they will not engage downstop lugs at the same height, carefully adjust vehicle level until the lifts are at the same height. See figure 4 and 5 for downstop pawl and lug identification.

### **Pinning the Lifts as Stands**

1. With the vehicle 2"-4" above the final working height, carefully lower the lifts by pushing both the air control levers down at the same time until the downstop pawls engage the closest downstop lugs.
2. Visually confirm that the downstop pawls are securely engaged on the downstop lugs of each lift and the raised axle is level (see Figure 5).
3. On both lifts, remove the load retention pin from its holder and insert it through the oblong hole in the lift stop bar and fully into the corresponding hole in the downstop lug (see Figure 6) to pin the lifts as stands.
4. Exhaust all air from both cylinders by pushing both air control levers down at the same time.
5. Disconnect the air hoses and coil them on the hose holders on the back of each lift.

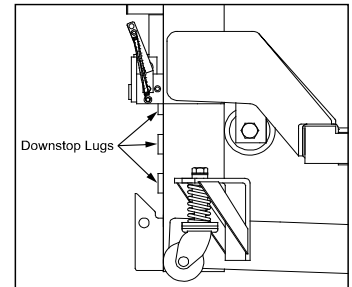

**Figure 4**  
Downstop lug identification.

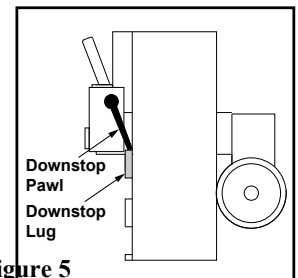

**Figure 5**  
Downstop pawl and lug identification.

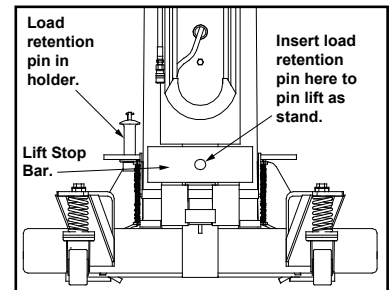

**Figure 6**  
Load retention pin.



## Lowering a Vehicle to the Ground

### **WARNING**

To prevent serious injury or death from a falling vehicle, operate *both* air control levers *at the same time* and keep the vehicle level as it is raised or lowered.

### **WARNING**

To prevent serious injury or death, clear the work area of all tools and equipment. Make sure all personnel are clear before lowering a vehicle.

1. Use this lift to lower the vehicle only if you used it to lift the vehicle. Using this lift to lower a vehicle that was raised with another device (or multiple devices) could overload the lift to the point of catastrophic failure.
2. Remove the load retention pins and insert them into their holders.
3. Uncoil the air hoses from both lifts. Be sure the air hoses are free from all pinch points.
4. Position yourself at the front or rear of the vehicle so both lifts are visible. Face the vehicle and hold the air control unit with the air control levers pointing toward the vehicle and the quick couplers at the bottom of the air control unit.
5. Connect the air hose from the lift on your right to the right side of the air control unit and the air hose from the lift on your left to the left side of the air control unit (see Figure 3).
6. Connect the air supply to the air inlet port of the air control unit (see Figure 3).
7. Raise both lifts slightly (about 1/2") so the downstop pawls are raised above the downstop lugs.
8. At each lift, release the downstop pawl by pushing the downstop release handle toward the lift (see Figure 7.)
9. Lower the lifts by pushing both the air control levers down at the same time. Be sure to operate the air control levers so the vehicle stays level. Lower the lifts to their lowest position do the downstop pawls will automatically reset.

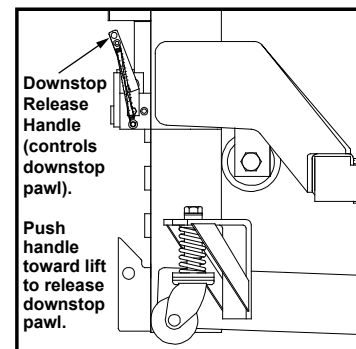

**Figure 7**  
Step 7. Push downstop release handle toward lift.

### **CAUTION**

If you decide to raise the vehicle again before it has been fully lowered, you must reset the downstop pawls. To manually reset the downstop pawls, pull the downstop release handle toward you on each of the lifts. (See figure 7).

10. Place the vehicle transmission in gear (or park) and engage the brakes.
11. Disconnect the air hoses and coil them on each lift.
12. Move the lifts away from the work area.

## Using the Lifts with Support Stands Transferring a Load to Support Stands

### **WARNING**

To prevent serious injury or death from a falling vehicle, never put any part of your body under a vehicle supported by Lift system unless the lifts have the load retention pins properly inserted to pin the lifts as stands.

### **WARNING**

To prevent serious injury or death from a falling vehicle, operate *both* air control lever *at the same time* and keep the vehicle level as it is lowered.

### **WARNING**

Vehicles that are not supported evenly may shift and fall. To avoid serious injury or death by crushing, make sure that the stands used are the same height, and that they are positioned at the manufacturer's recommended locations the same distance from the lifts on each side of the vehicle.

After the vehicle has been raised (following instructions under the "Raising a Vehicle" section) and the wheel lifts have been pinned as stands ("Pinning the Lifts as Stand," section) you can transfer the vehicle to support stands and remove the wheel lifts, if you choose.

1. Select stands of the same height for each side of the vehicle. Make sure the stands are capable of supporting the weight of the vehicle.
2. Identify appropriate manufacturer recommended locations, suitable for supporting the vehicle on stands, an equal distance from the lifts on each side of the vehicle.
3. Clear the work area under the vehicle of all personnel, then place the stands at the appropriate locations on each side of the vehicle.
4. Remove the load retention pins and lower the vehicle down onto the support stands (if the load retention pins will not pull out easily, raise the vehicle just enough to free the load retention pins). Make sure the vehicle comes down *evenly* on the stands.
5. When the vehicle is securely supported by the support stands, lower the lifts to their lowest position so the downstop pawls are automatically reset.

### **CAUTION**

The downstop pawls will not automatically reset until lift has been fully lowered. If the lift is used without being lowered completely first, you must manually reset the downstop pawls by pulling the downstop release handle toward you on each of the lifts.

6. Disconnect the air hoses and coil them on the air hose holders on the back of each lift. Pull the lifts away from the work area.

## **Removing Support Stands**

1. Move the lifts into place at opposite ends of the axle to be lowered and position them so the lift pads will cradle the tires when contact is made.
2. Carefully follow steps 7-10 under “Preparing the Lifts and Vehicle,” section.
3. To raise the lifts, pull up on both air control levers at the same time. Operate the air control levers so both of the lift pads contact the tires at the same time.
4. Visually confirm that both lift pads have securely engaged the tires, and that the lift table tube of each lift contacts the side of the tire.
5. Raise the vehicle off the support stands by lifting up on both the air control levers at the same time. Be sure to operate the air control levers so the vehicle stays level.
6. Pin the lifts as stands, carefully following the instructions in “Pinning the Lifts as Stands,” section.
7. Once the lifts have been pinned as stands, remove the support stands from under the vehicle; then lower the vehicle, following the instructions under “Lowering A Vehicle To The Ground,” section.

# Maintenance Instructions

## **WARNING**

To prevent serious injury or death from a falling vehicle, all inspection and maintenance procedures must be performed *after* the jack has been removed from service. Position the lifts so you have clear access to all sides of the lift for inspection and service.

The owner must inspect, or appoint a knowledgeable person to inspect, the jack. Visual inspection should be made before each use of the lift, checking for abnormal conditions. Regular inspections should be made weekly for daily use and monthly for intermittent use. Each lift must be inspected immediately if subjected to an abnormal load or shock. Any lift which appears to be damaged in any way, is found to be badly worn, or operates abnormally shall be removed from service until necessary repairs are made.

1. All warning and capacity labels should be readable and complete. Wash external surfaces of jack, labels, and decals with a mild soap solution.
2. Lubricate all rotating and sliding portions of the jack monthly.

### Lubrication

**Figure 8**  
Lubrication points

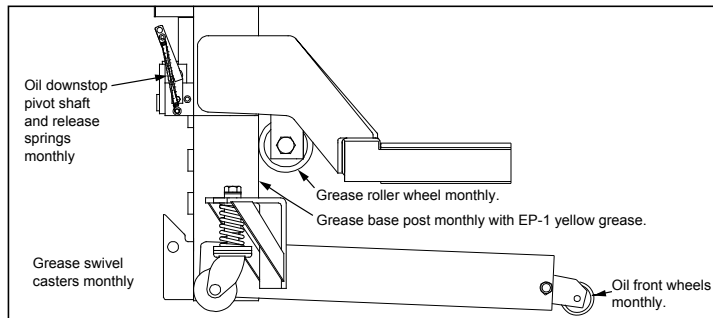

### Lift Table Adjustment

The lift system has a 1/2-13 hex head capscrew mounted inside the top weldment to allow the lift table to be raised or lowered slightly. The capscrew has been adjusted at the factory to provide 1/4" to 5/16" of clearance between the bottom of the lift pads and the floor.

To raise or lower the lift table, follow the lift table adjustment steps below:

1. Place the lifts on a level floor in a suitable open area.
2. Raise both lifts onto their lowest downstop.
3. Loosen the jam nut and turn the capscrew a few turns in the required direction. (See Figure 9 for identification. Configuration may vary)
4. Tighten the jam nut.
5. Lower the lift to its lowest position and check the lift table height above the floor. Also, ensure that the downstop automatically reset into the locked position.

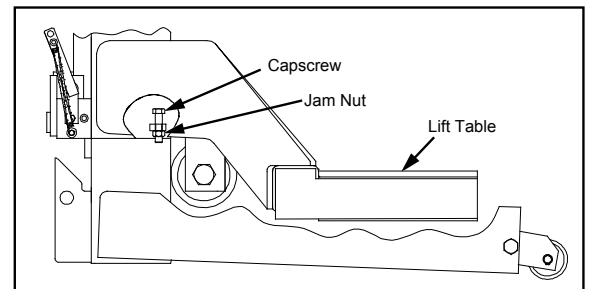

**Figure 9**

*Lift table clearance adjustment.*

Repeat the adjustment as needed until each lift has a minimum of 1/8" clearance between the lift table bottom and the floor. With the lift table resting on the floor, the lifts may not easily move around the shop floor. Do not raise the lifts to the point that the downstop does not reset.

### Air Control Unit Cleaning Instructions

Occasionally, pieces of rust, scale or dirt from the air lines may become lodged under the rubber seals of the air control unit. This may cause minor air leakage and the lift system units may slowly raise or lower even though the air control levers have not been actuated. This minor air leakage is easily corrected by following the steps below (refer to Figure 10 for component identification):

1. Disconnect the three air hoses attached to the air control unit.
2. Remove the valve bracket.
3. Remove the plug or plugs.
4. Use a stiff wire or pin punch to push the spool out of the valve body.
5. Carefully examine the rubber seal for any dirt or foreign material. If foreign material is embedded in the rubber seal, remove the screw and cup from the end of the spool, then remove and clean the rubber seal. Turn the seal over and reassemble it into the cup. Secure the cup back onto the end of the spool with the screw.
6. Lubricate the spool with a light chassis grease.
7. Insert the spool with O-ring into the air inlet spool port.
8. Insert the spool without O-ring into the air exhaust spool port.
9. Insert the spring(s).
10. Apply thread sealant to the plug(s) and install the plugs into the valve body. Do not over tighten the plug(s), as the threads can very easily be damaged.

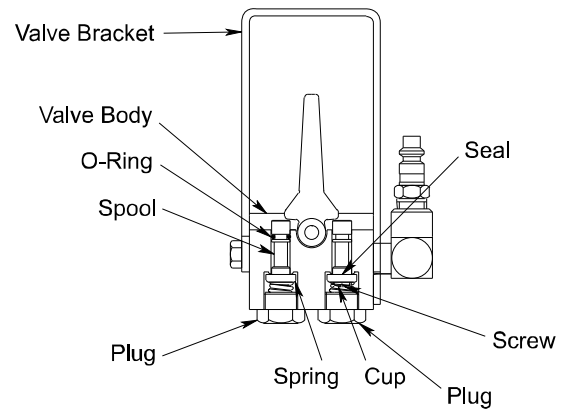

**Figure 10**

Air Control Unit component identification.

## Structural Inspection



### WARNING

To prevent serious injury or death from a falling vehicle, all inspection and maintenance procedures must be performed *after* the jack has been removed from service. Position the lifts so you have clear access to all sides of the lift for inspection and service.



### WARNING

The jack must be removed from service and inspected for damage immediately if the jack is subjected to an abnormal shock or load. Never return the Lift system to service until all damaged components have been properly repaired or replaced. Always test the lift and verify proper operation before returning the Lift system to service. Failure to heed this warning may result in personal and / or property damage.

### NOTICE

The owner must inspect, or appoint a knowledgeable person to inspect the jack for signs of corrosion and / or excessive wear. Visual inspection should be made before each use of jack, checking for abnormal conditions. Regular inspections should be made weekly for daily use and monthly for intermittent use. Each jack must be inspected immediately if subjected to an abnormal load or shock. Any jack which appears to be damaged in any way, is found to be badly worn, or operates abnormally shall be removed from service until necessary repairs are made.

1. Inspect the lifts for any cracks, chips, or signs of excessive wear. Visually inspect the welds.
2. Inspect the load retention pins for deformities or excessive wear — if the deformities or wearing away of material are easily noticeable without close inspection, it is excessive.

Test the load retention pins by inserting them through the lift stop bar and into each downstop lug. If the load retention pin cannot be inserted fully through the lift stop bar and into each of the holes in the downstop lugs in all positions, it is excessively damaged and must be replaced before the lift can be used again.

3. Inspect the holes for the load retention pins in the base post. If these holes show excessive elongation or wear on the top or bottom surfaces, they must be repaired before the lift can be placed back into service. Contact the manufacturer using the contact information on the back cover of this manual for repair recommendations.

If any irregularities or problems are detected during an inspection, the jack must be removed from service immediately and repaired. Contact the manufacturer using the contact information on the back cover of this manual.

## Air Hose Inspection



### WARNING

To prevent serious injury or death from a falling vehicle, or possible serious injury due to bursting air hoses, replace air hoses only with single-wire reinforced air hoses from manufacturer, part number 1-271-02002. The use of any other air hose increases the risk that the air hose may become pinched or damaged, resulting in failure of the air hose or of the lift during operation. Contact the manufacturer.

Inspect the air hoses daily for any signs of cuts, abrasions, or excessive wear. If any air hose appears to be damaged, replace it immediately with manufacturer authorized reinforced steel air hose, part number 1-271-02002.

Inspect the air fittings daily for cracks and/or damaged parts. If any show damage, replace them before putting the Lift system back into service.

# Troubleshooting

This section is a list, in which may be encountered and their solutions. If the solution listed fails to correct the problem, contact the manufacturer using the contact information on the back cover of this manual. Please have the model number, and serial number of your jack available. The serial number is printed on a tag located on one of the caster brackets.

<u>PROBLEM</u>	<u>CAUSE / SOLUTION</u>
Will not raise load .....	Inadequate air pressure, requires 145-psi.  Lifts are overloaded. Rated capacity is printed on a tag located on one of the caster brackets. Use other lifting means.  Air hoses are not connected properly, damaged, or pinched.  Air control unit is dirty or damaged. See the “Air Control Unit Cleaning Instructions” section of this manual.
Only one lift raises.....	Air hose is not connected properly, damaged, or pinched.  Air control unit is dirty or damaged. See the “Air Control Unit Cleaning Instructions” section of this manual.
Will not cradle tire.....	Tire is under-inflated or tire diameter is too large.  Lift is not fully lowered.  Vehicle is overloaded. Use other lifting means.
Lift will not lower or lowers erratically.....	Vehicle parking brake is set and/or transmission is in gear.  Air hoses are not connected properly.  Air hoses are pinched. Remove load from lifts using other lifting means; remove air hoses from pinch point.
Lift table hits floor.....	Floor is uneven and/or rough. Raise lift to lowest downstop.  Lift table height needs adjustment for minimum clearance. See the “Lift Table Adjustment” section of this manual.
Lift raises slowly .....	Low air pressure. Raise air pressure to 145 psi.  Air control unit is dirty or damaged. See the “Air Control Unit Cleaning Instructions” section of this manual.  Lifts overloaded. Rated capacity is printed on a tag located on one of the caster brackets. Use other lifting means.