

MIDRISE & SHORT-RISE LIFTING SOLUTIONS



MR6 | 6,000 LB. CAPACITY

» Portable mid-rise lift

Challenger's midrise lift is a great way to increase the productivity of any shop. We mounted the motor to a heavy-duty tow dolly, making it portable and able to operate on concrete, indoors or out. Save valuable shop space while servicing brakes or tires. 6,000 lb. capacity will lift vehicles from small passenger cars to light trucks.

SRM10 | 10,000 LB. CAPACITY

» Short-rise lift

Challenger's shortrise lift is a great choice for brake and tire servicing needs. Dual hydraulic cylinders provide a 10,000 lb. capacity to lift vehicles ranging from small passenger cars to light trucks. Standard spotting blocks and optional auxiliary adapters reach an even wider range of vehicle lift points. The SRM10's small footprint compared to other lift models make the SRM10 a perfect fit.



CL Challenger Lifts

LOUISVILLE, KENTUCKY

SHORTRISE LIFT

Model Number	SRM10
Lifting Capacity	10,000 lbs. (4,536 kg)
A Rise Height	22" (559 mm)
Lowered Height	4.25" (108 mm)
Locking Bar Heights	13.75", 18.325", 21.25" (349/465/540 mm)
B Low Adapter Position	4.75" (121 mm)
C High Adapter Position	6.75" (171 mm)
D Overall Width	85" (+ 2.5" for handle) / 216 cm (+ 64 mm for handle)
E Outside Width of Platforms	72" (183 cm)
F Width between Platforms	23" (584 mm)
G Platform Overall Length	50" (127 cm)
H Ramp & Platform Overall Length	82.5" (210 cm)
I Overall Length	92.875" (236 cm)
Rearward Movement	13.25" (337 mm)
Std. Motor/Voltage	1HP 115v, 60Hz, 1Ph
ALI/ETL Certified	✓
Colors Available	Red, Blue

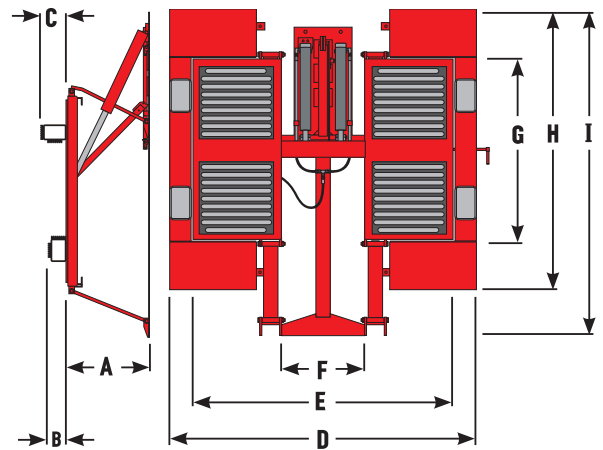

ACCESSORIES



Four 4-1/8" spotting block auxiliary adapters
Part#: 63100



Four 1-1/2" spotting block auxiliary adapters
Part#: 10549-04

MIDRISE LIFT

LOCKING POSITIONS:

	49 ³ / ₄ "
	45 ⁵ / ₈ "
	41 ¹ / ₄ "
	36"
	30"
	22 ⁷ / ₈ "

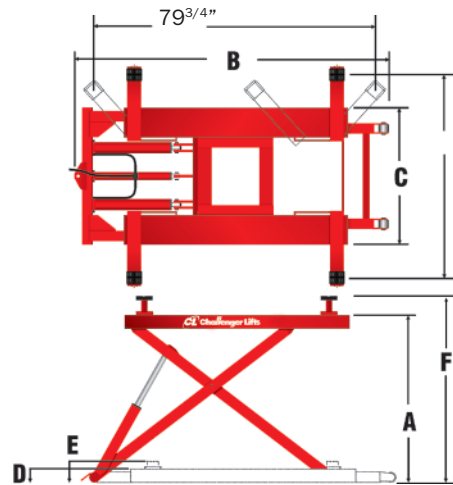

Model Number	MR6
Lifting Capacity	6,000 lbs. (2,422 kg)
A Rise Height	52.75" (134 cm)
B Overall Length	94" (239 cm)
C Overall Width	40" (102 cm)
D Min. Collapsed Table Height	5.5" (140 mm)
E Pad Height (Min.)	8.625" (359 mm)
F Pad Height (Max.)	60" (152 cm)
Hydraulic Hose	144" (366 cm)
Safety Lock Positions	6
Std. Motor/Voltage	1HP, 115V, 60Hz, 1Ph
Speed of Rise	45 s
Min. Rec. Bay Size	10' x 22' (305 cm x 671 cm)
Colors Available	Black

For more information, contact your Authorized Challenger Lifts Distributor:

800-648-5438 | 502-625-0700 | Fax: 502-625-0711 | Email: sales@challengelifts.com
2311 South Park Road | Louisville, KY 40219

