

CL Challenger Lifts

Parts List

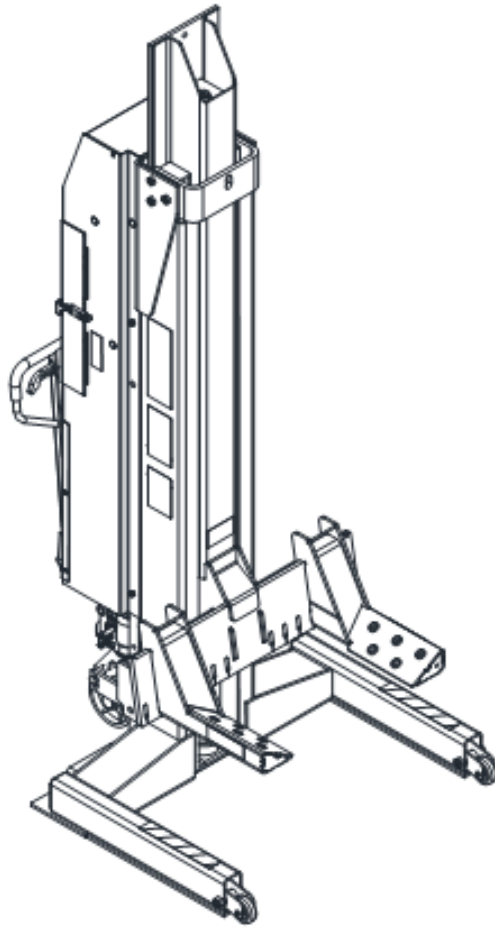

CLHM-190

WIRELESS PORTABLE LIFT SYSTEM

Email: sales@challengerlifts.com Web site: www.challengerlifts.com

Office 800-648-5438 / 502-625-0700 Fax 502-587-1933

Table of Contents

- CLHM-190 Assembly3
- Front Caster Arm Subassembly & Hydraulic Handle Subassembly.....5
- Hydraulic Power Unit6
- Electrical Components7
- Placards9

CHLM-190 Assembly

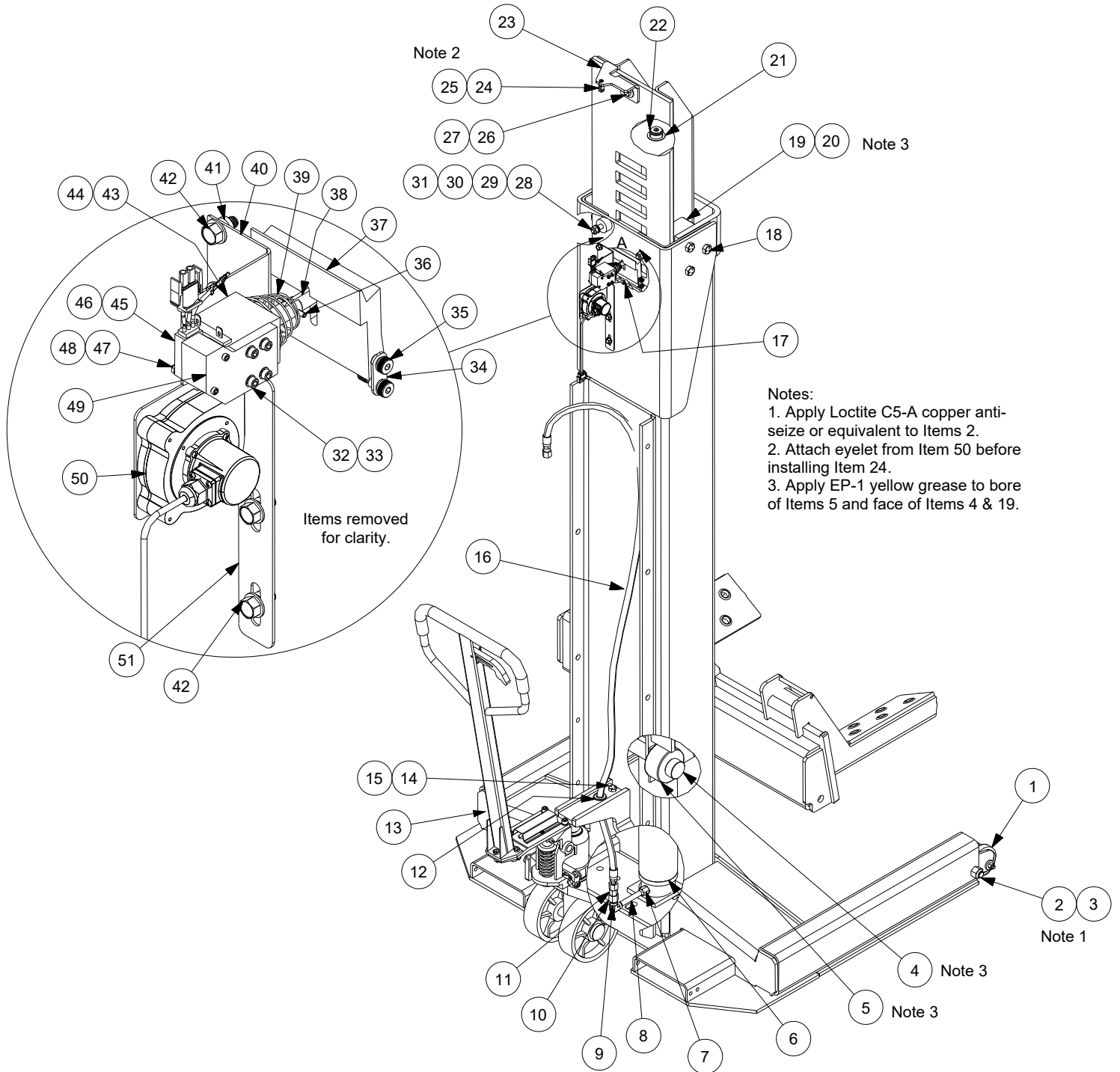

CHLM-190 Assembly

ITEM	QTY	PART NUMBER	DESCRIPTION
1	2	957-01020	Front Caster Arm Subassembly (See Page 4)
2	2	200-31718	Capscrew, Hex Hd, 3/4-10 UNC, Stl, Gr 5, Pl, 4" Lg
3	2	203-01710	Nut, Hex, 3/4-10UNC, Grade 5, Steel, Plated, Self Locking Insert
4	2	957-04046	Spacer, Bottom
5	2	480-01021	Roller Wheel
6	1	353-45026	Cylinder, Hydraulic
7	1	274-12020	Adapter, Straight, -6 SAE O-Ring Male X 1/4 NPT Female
8	1	275-01044	Nipple, 1/4 NPT, 4" Long, Schedule 80, Steel
9	1	275-11011	Elbow, 1/4 NPT Female X 1/4 NPT Female, Steel
10	1	274-12017	Adapter, Straight, -6 SAE O-Ring Female X 1/4 NPT Male
11	1	353-60002	Flow Limiter, -6 SAE O-Ring X -6 ORS, 1.2 GPM
12	1	390-90005	Grommet, Rubber, 13/16 ID, 1-3/8 OD, 3/4 Th, 1.000 Panel Hole
13	1	936-04094	Hydraulic Handle Assembly (See Page 4)
14	4	200-31409	Capscrew, Hex Hd, 1/2-13 UNC, Stl, Gr 5, Pl, 1-3/4" Lg
15	4	203-01403	Nut, Hex, 1/2-13, Steel, Plated, Grade 5, Nylon Self Locking
16	1	271-24013	Hose Assembly, 3/8" X 86.000" Long
17	2	400-50000	Grease Fitting, 3/16 Drive
18	6	200-31607	Capscrew, Hex Head, 5/8 - 11UNC, Steel, Grade 5, Plated, 1-1/4" Long
19	2	441-59032	Bearing, Plain, Linear Slide Block, UHMW, WPLS
20	2	957-04178	Slide Block Core
21	1	204-02201	Washer, 1-7/8 O.D. X 1-3/8 I.D. X 1/16, Steel, Plated
22	1	230-14002	Retaining Ring, External, 1-1/4" Dia.
23	1	957-04154	Position Transducer Cable Mount Bracket
24	1	232-10021	Rod End, Clevis, 10-32 Female Thread, Plastic
25	1	202-00829	Screw, Pan Head, 10-32UNF, 3/8" Long, w/ Ext Lock Washer, Stl, Black
26	4	200-31409	Capscrew, Hex Hd, 1/2-13 UNC, Stl, Gr 5, Pl, 1-3/4" Lg
27	1	204-01403	Washer, Flat, 1/2, Type A, Wide, Steel, Plated
28	2	201-41401	Capscrew, Socket Hd, 1/2-13 UNC, Stl, Pl, 1.500" Long
29	2	203-01400	Nut, Hex, 1/2-13 UNC, Reg. Steel, Plated
30	2	204-11400	Washer, Lock, 1/2, Split Type, Steel, Plated
31	2	441-59030	Bearing, Plain, Linear Slide Pad, UHMW, Ø1.500 OD X .530 ID
32	4	201-00702	Capscrew, Socket Hd, #8-32 UNC, Stl, Pl, 1/2" Long
33	8	204-20701	Washer, Lock, #8 Internal Tooth, Type A, Stl, Pl
34	2	957-04105	Downstop Linkage
35	4	202-81000	Shoulder Bolt, 1/4-20, 5/16 Shoulder X 3/8 Lg, Stl
36	1	235-20002	Roll Pin, 1/8 Dia. X 1" Long
37	1	957-04177	Downstop
38	1	957-04179	Solenoid/Downstop Connecting Link
39	1	233-19004	Spring, Compression, Conical, .840 X 1.125 O.D.
40	1	957-04079	Down Stop Solenoid Bracket
41	4	203-61101	Threaded Insert, Rivet Nut, 5/16-18 UNC, .615 Lg, Steel
42	4	202-01106	Capscrew, Hex Hd, Flange Lock, 5/16-18 UNC, Gr 5, Plt, 5/8 Lg
43	1	591-00110	Solenoid, Encapsulated, 24 VDC, w/ Custom Plunger
44	4	201-00700	Capscrew, Socket Hd, #8-32 UNC, Stl, Pl, 1/4" Long
45	1	593-20177	Wire Assembly, Down Stop Switch
46	1	936-04172	Down Stop Switch Plunger
47	2	201-00408	Capscrew, Socket Hd, #4-40 UNC, Stl, Pl, 1.500" Long
48	2	203-00501	Nut, Hex, #4-40 UNC, Self Locking
49	1	936-04175	Down Stop Switch Mounting Block
50	1	591-00100	Position Transducer, String Potentiometer
51	1	957-04153	Position Transducer Bracket, Upward Cable Feed

Front Caster Arm Subassembly & Hydraulic Handle Subassembly

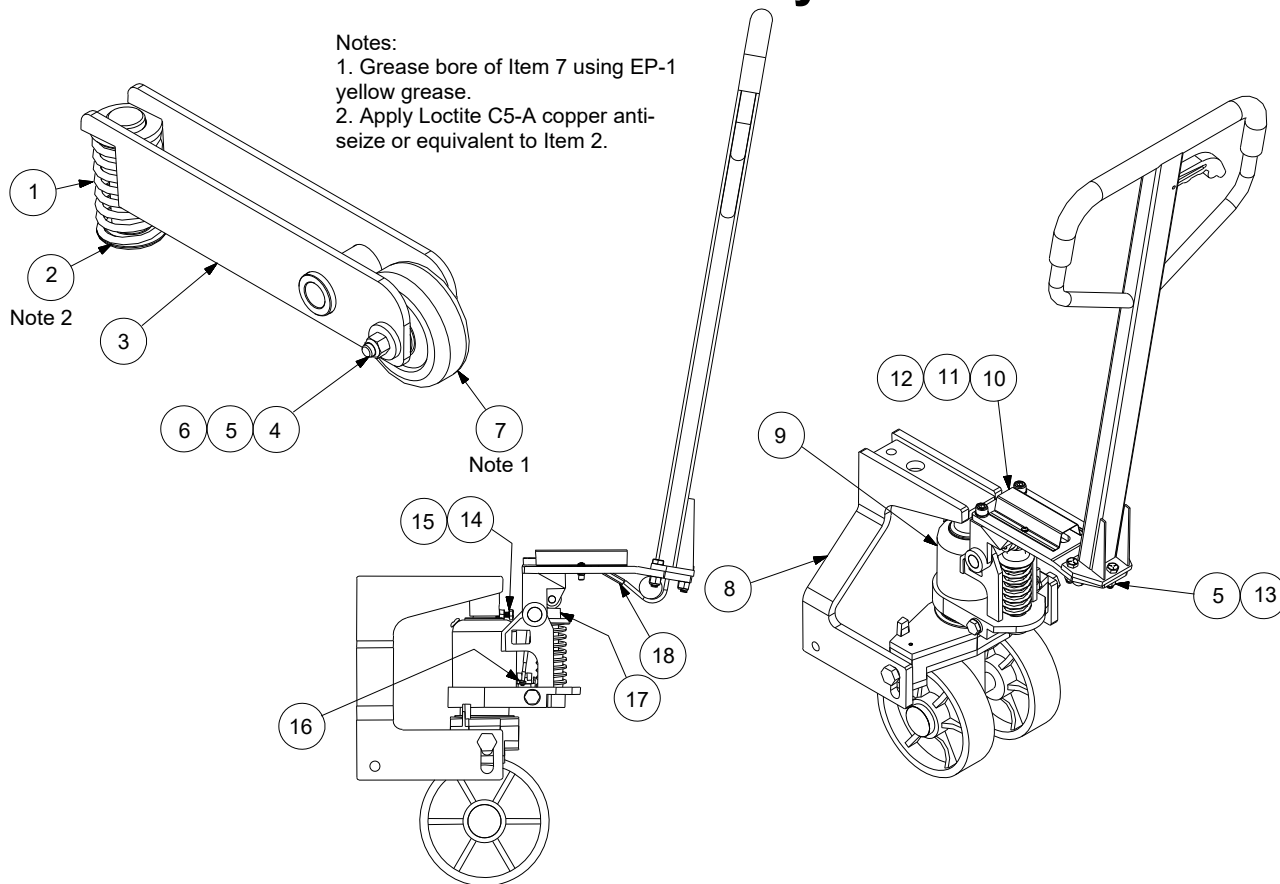

ITEM	QTY	PART NUMBER	DESCRIPTION
1	1	233-15008	Spring, Compression, 1.937 O.D., 4" Free Length
2	1	936-04089	Spring Guide Pin
3	1	957-02013	Caster Pivot Arm Weldment
4	1	202-80002	Bolt, Shoulder, 3/8-16 UNC X 1/2 Dia X 2 1/4 Lg Shoulder, Stl, Pl
5	4	203-01202	Nut, Hex, 3/8 - 16UNC, Steel, Plated, Self Locking
6	1	204-01414	Washer, Flat, 1/2", Type A, Narrow, Extra Thick
7	1	480-00035	Wheel, 3 1/2 O.D. X 1/2 Bore
8	1	936-02007	Handle Bracket Weldment
9	1	936-04094	Hydraulic Handle
10	1	936-04235	Chain Cover
11	2	202-00826	Screw, Pan Head, 10-32UNF, 5/8" Long, w/ Ext Lock Washer, Stl, Black
12	2	203-60802	Threaded Insert, Rivet Nut, 10-32 UNF, .475 Lg, Steel
13	3	200-31207	Capscrew, Hex Head, 3/8-16UNC, Steel, Grade 5, Plated, 1 1/4" Long
14	1	200-31106	Capscrew, Hex Head, 5/16 - 18UNC, Steel, Grade 5, Plated, 1" Long
15	1	203-01101	Nut, Hex, 5/16 - 18UNC, Regular, Steel, Plated
16	1	203-00805	Nut, Hex #10-24UNC, Steel, Plated, Nylon Insert (Locknut)
17	1	936-04236	Plunger Cap
18	1	936-04234	Handle Release Cable Extension

Hydraulic Power Unit

Notes:

1. Cartridge torque range: 24-26 ft-lb.
2. Cartridge torque range: 19-21 ft-lb.
3. Solenoid coil nut torque range: 5-7 ft-lb.
4. Apply EP-1 yellow grease.
5. Apply removable thread locker to Item 18 and torque to 15-19 ft-lb.

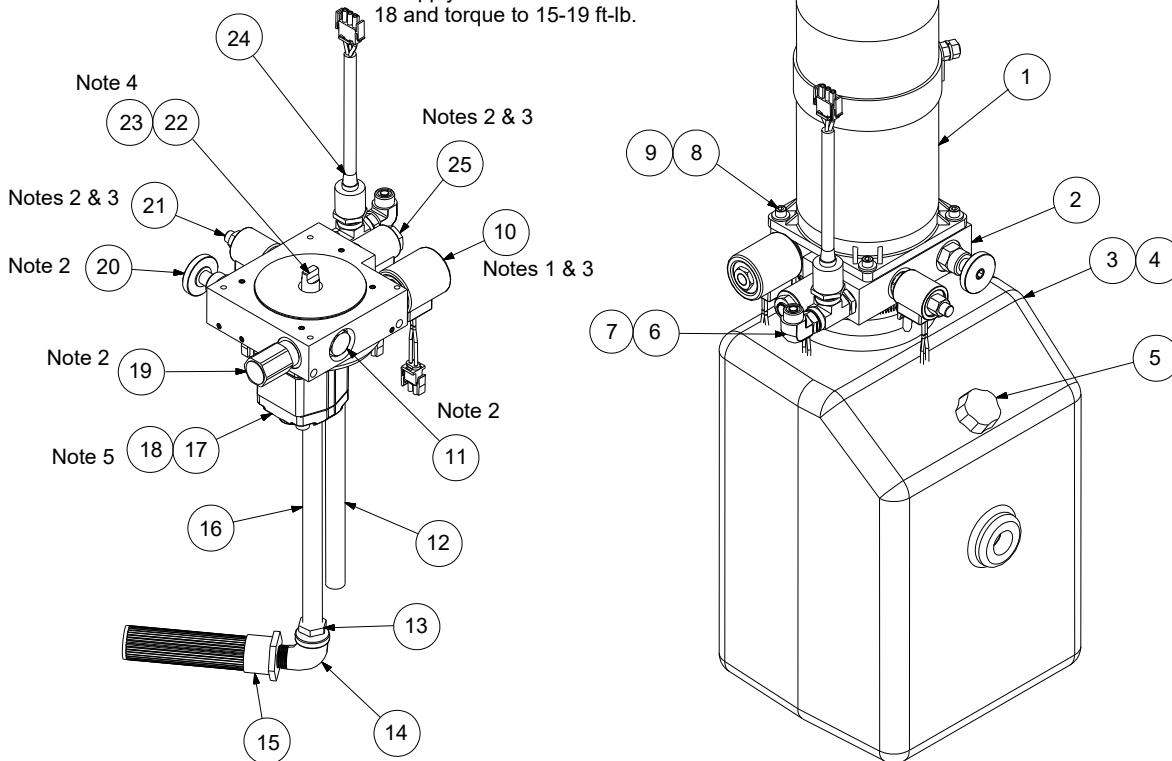

Item	QTY	PART NUMBER	DESCRIPTION
1	1	591-00068	24 VDC Motor
2	1	353-49387	Hydraulic Pump Block
3	1	353-60012	Reservoir, Poly, 9 X 10 X 16
4	1	231-06001	Clamp, Hose, Screw Adjustable, 3.750 - 4.625 Dia.
5	1	353-60013	Breather, 3/4" NPT
6	1	274-06001	Adapter, 90 Deg, -6 SAE O-Ring Male X -6 ORS Male
7	1	274-22003	Adapter, Tee, -6 SAE O-Ring Male X Female X Female
8	4	201-01002	Capscrew, Socket Head, 1/4-20UNC, Steel, 5/8" Long
9	4	204-01005	Washer, Flat, 1/4 Narrow Rim, Steel, Plated
10	1	353-50021	Dump Valve, 24 VDC
11	1	353-50009	Check Valve
12	1	353-49406	3/8 NPT Pipe Nipple, SCH 80, PVC, 12" Lg
13	1	275-23001	Bushing, Reducing, 1/2 NPT X 3/8 NPT
14	1	275-13001	Elbow, Street, 1/2 NPT
15	1	353-60014	Tank Mount Strainer, 1/2" NPT X 1" NPT
16	1	353-49407	3/8 NPT Pipe Nipple, SCH 80, PVC, 10" Lg
17	1	353-10001	Hydraulic Gear Pump, 2.1 cc/rev
18	2	201-01116	Capscrew, Socket Head, 5/16-18UNC, Steel, 3" Long
19	1	353-50005	Relief Valve
20	1	353-50008	Needle Valve
21	1	353-50022	Holding Valve, 24 VDC
22	1	353-60008	24V Coupler
23	1	353-60007	Motor Coupler Sleeve
24	1	353-60006	Pressure Transducer, 0-3500 psi
25	1	353-50020	Proportional Valve, 24 VDC

Electrical Components

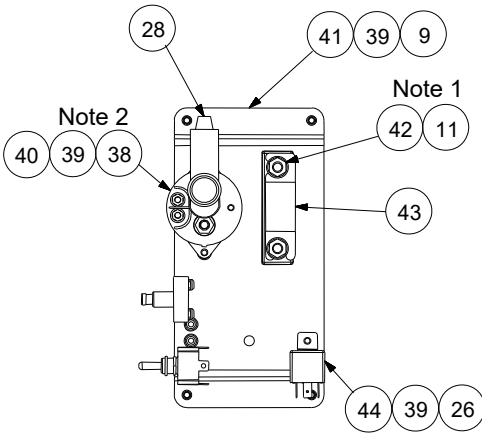
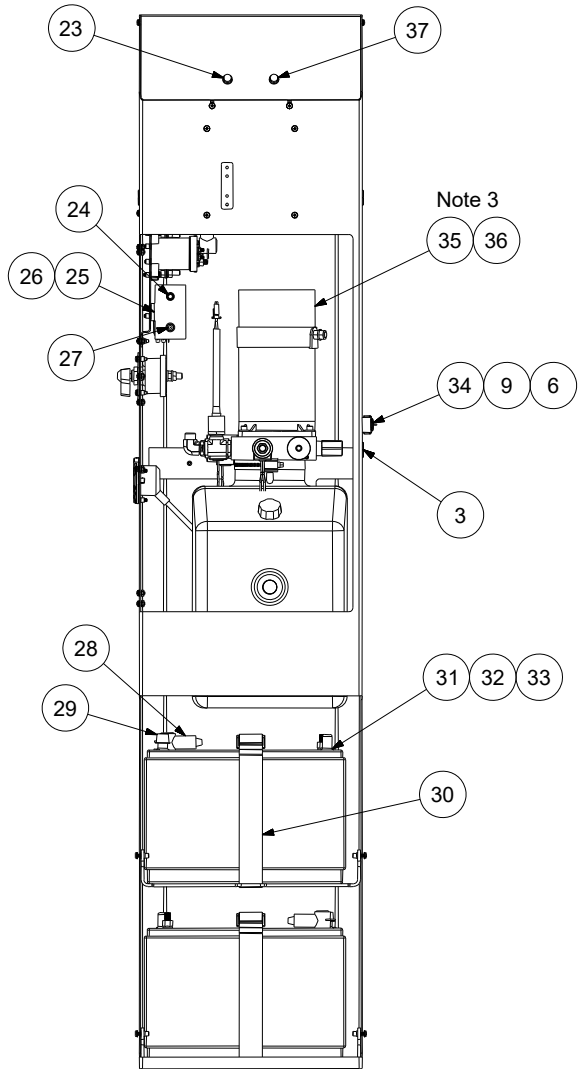
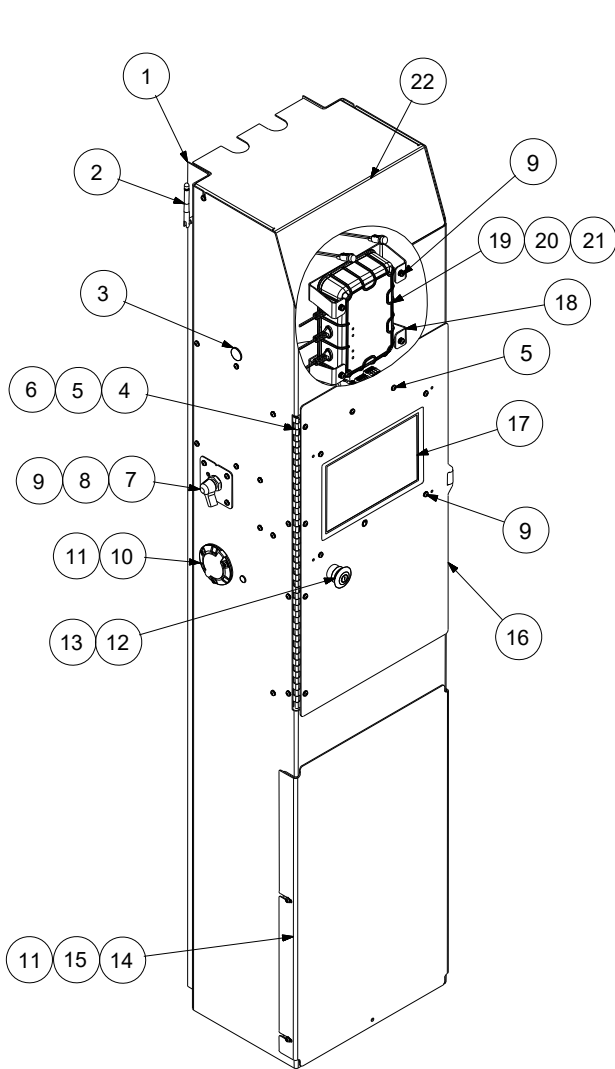

- Notes:
1. Torque nuts on Item 42 to 72-90 in-lb after installing Item 43.
 2. Torque 10-32 nuts on Item 38 to 15-30 in-lb. Torque M8X1.25 nuts on Item 38 to 80-100 in-lb.
 3. Torque motor nuts on Item 35 to 96-120 in-lb after installing motor cables.

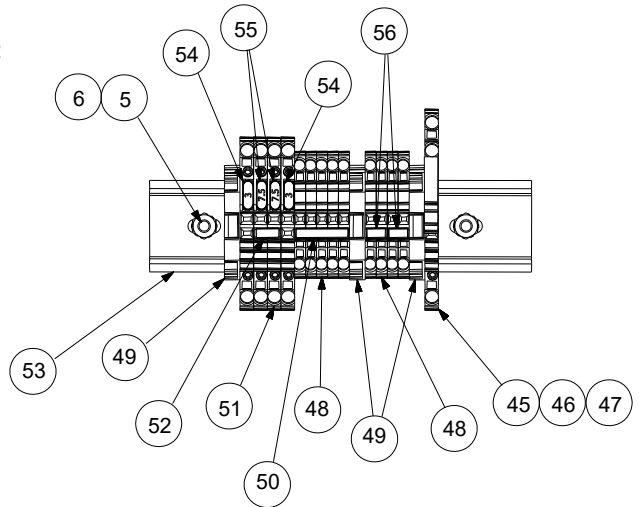

Electrical Components

ITEM	QTY	PART NUMBER	DESCRIPTION
1	1	957-02027	Cabinet Weldment, 10.1" Screen
2	1	593-10062	RF Antenna, 2.4GHz, RP-SMA Male
3	5	591-00053	Plug, Enclosure Ø.750
4	1	957-04101	Hinge, Top Cover
5	17	202-00829	Screw, Pan Head, 10-32UNF, 3/8" Long, w/ Ext Lock Washer, Stl, Black
6	18	203-10802	Nut, Hex, w/ External Lock Washer, 10-32, Stl, PI
7	1	591-00127	Switch, Battery, Single Circuit
8	1	957-04159	Battery Switch Conversion Plate, Blue Sea - Cole Hersee
9	20	202-00826	Screw, Pan Head, 10-32UNF, 5/8" Long, w/ Ext Lock Washer, Stl, Black
10	1	591-00111	Charger Inlet w/ Cord
11	9	202-00824	Screw, Pan Head, 10-32UNF, 3/4" Long w/Ext Lock Washer, Stl, Blk
12	1	591-00142	Switch, E-Stop, Push-Pull, 22 mm
13	2	591-00143	Contact Block, Normally Closed
14	1	957-04169	Lower Cover, 10.1" Screen
15	4	203-60804	Threaded Insert, Rivet Nut, 10-32 UNF, .585 Lg, Steel
16	1	957-04167	Cabinet, Door, 10.1" Screen
17	1	593-30095	Control Box Assembly, Metal
18	1	957-04170	Mounting Bracket, Lester to NOCO Charger
19	1	591-00105	Battery Charger, Dual Bank, NOCO, 4A/Bank
20	4	202-00602	Screw, Pan Head, #6-32 UNC, Stl, PI, 1.000 Lg
21	4	203-00601	Nut, Hex, 6-32 UNC, Steel, Plated, Nylon Locknut
22	1	957-04168	Cabinet, Top, 10.1" Screen
23	1	593-30073	LED Subassembly, 24 VDC, Green
24	1	591-00013	Push Button Switch
25	1	957-04080	Switch Bracket
26	4	202-00819	Screw, Pan Head, 10-32UNF, Steel, 1/2" Long w/ External Lock Washer
27	1	591-00012	Toggle Switch
28	3	591-00085	Terminal Insulator Cap, 8-2 AWG, Red
29	2	680-00188	Cap Plug, 9X, Red
30	2	237-00006	Strap Assembly
31	2	591-00069	Battery, Group 31, Wet Cell
32	4	204-01109	Washer, Flat, 5/16" Dia., Type B, Narrow Rim, Stainless
33	4	204-11104	Washer, Lock, Split Type, 5/16", Stainless
34	1	957-04145	Latch, Draw, Lockable
35	1	353-40146	Power Unit Assembly, 24 VDC Valves
36	2	202-01235	Capscrew, Hex Head, Flange Lock, 3/8 - 16UNC, Plated, 3/4" Long
37	1	593-30074	LED Subassembly, 24 VDC, Yellow
38	1	591-00109	Series Contactor, 24 DC Coil
39	26	203-60802	Threaded Insert, Rivet Nut, 10-32 UNF, .475 Lg, Steel
40	2	202-00818	Screw, Pan Head, 10-32UNF, Steel, 1" Long with External Lock Washer
41	1	957-04074	Components Mounting Bracket
42	1	591-00065	Fuse Block, High Amp, UL Listed
43	1	591-00049	200 Amp Fuse
44	1	591-00108	Relay, SPDT, 24 VDC Coil
45	1	593-10132	Terminal Block, Carrier, 2+1 Pos, 22-12 AWG, WAGO
46	1	593-10133	Terminal Block, Component Plug, WAGO
47	1	593-02147	Diode, Schottky, 60 V, 1.0 A, Thru Hole
48	9	593-10128	Terminal Block, Feed Thru, 2 Conductor, 22-14 AWG, WAGO
49	3	593-10131	End Retainer, Screwless, 35mm DIN Rail, WAGO
50	1	593-10129	Jumper, Terminal Block, 5 Pole, WAGO
51	4	593-10134	Terminal Block, Fuse, 2 Conductor, 22-12 AWG, WAGO
52	1	593-10135	Jumper, Terminal Block, 2 Pole, WAGO
53	1	040-00021	DIN Rail, 35mm X 7.5mm, 5.746" Long
54	2	591-00144	Fuse, Blade, 3A, Mini/ATM Size
55	2	591-00137	Fuse, Blade, 7.5A, Mini/ATM Size
56	2	593-10130	Jumper, Terminal Block, 2 Pole, WAGO

Placards

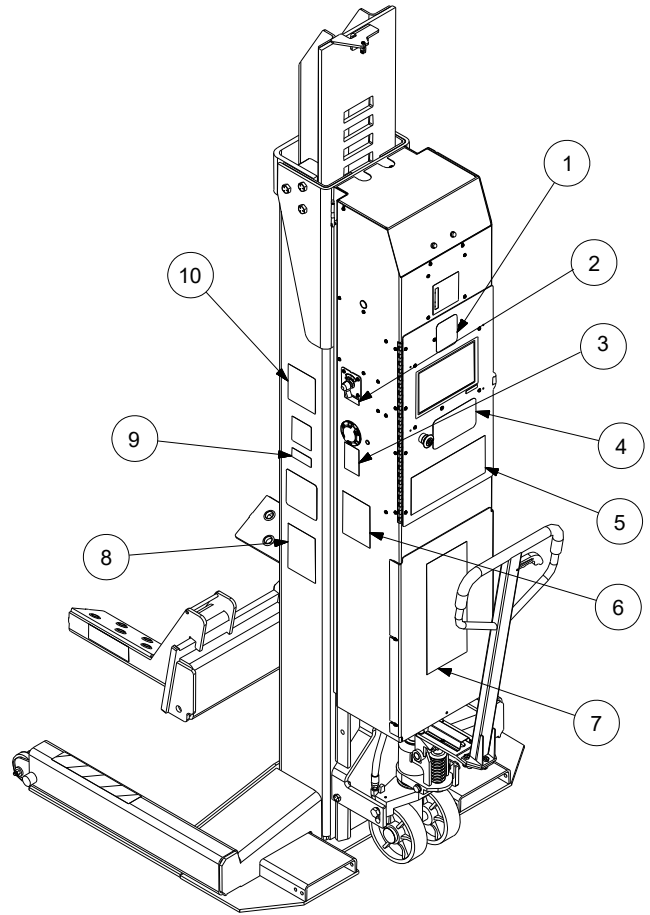
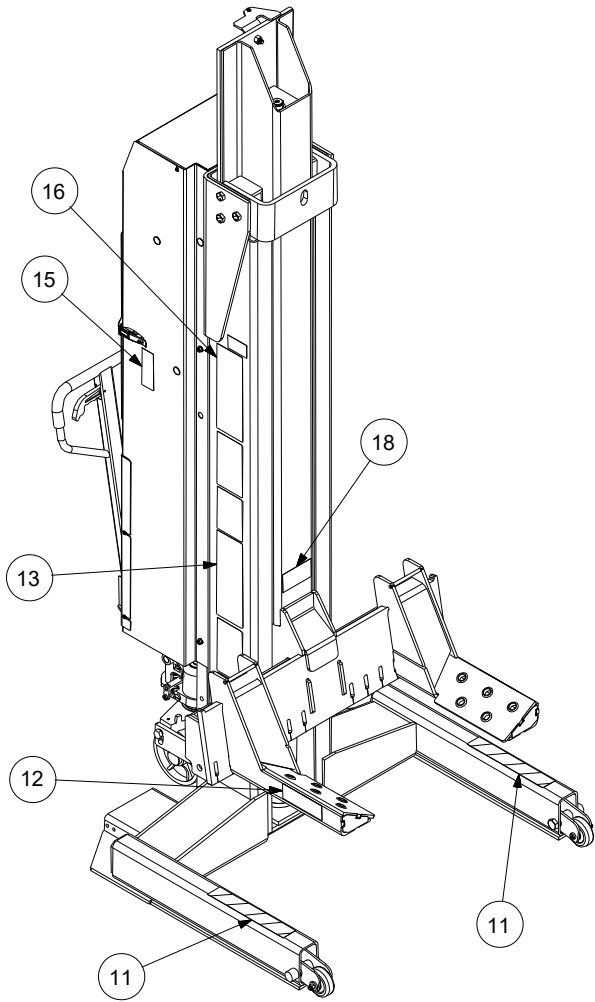

View Inside Cabinet Door

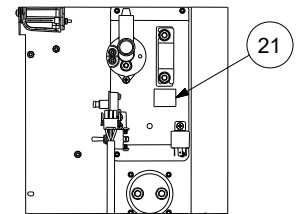
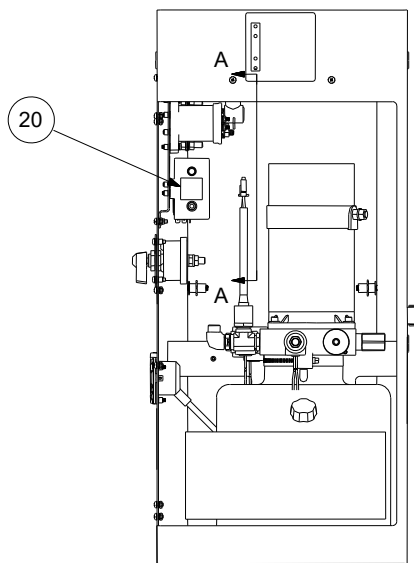
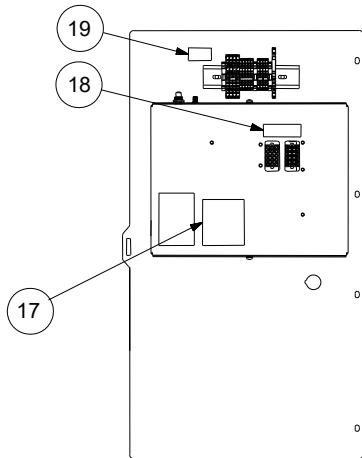

SECTION A-A

Placards

Item	QTY	PART NUMBER	DESCRIPTION
1	1	670-00030	Identification Placard, "G"
2	1	670-00309	ID Placard, Master ON/OFF Switch
3	1	670-00310	Identification Placard, Battery Charger Cord Socket
4	1	670-00585	Identification Placard
5	1	670-10518	Information Placard, Original Wireless
6	1	670-10655	Information Placard, Emergency Procedures, 10.1" Screen
7	1	670-10437	Information Placard, Warning Decal
8	1	670-10474	Information Placard, Warning, Arcing Parts
9	1	670-10505	Information Placard, ALI Member
10	1	670-10567	Information Placard, Maintenance Instructions
11	2	670-10561	Safety Tape, Vinyl, 2" Wide, Yellow/Black, 12" Long
12	2	670-10359	Information Placard, Warning
13	1	670-10636	Placard Kit, ALI/WL 400, French
14	1	670-10472	Information Placard, Caution, Fuse Replacement
15	1	670-10491	Placard Kit, ALI/WL 400
16	1	670-10569	Info Placard, Warning, Tire Engagement
17	1	670-10473	Information Placard, Caution, Control Box
18	1	670-10630	Information Placard, Control Box Plugs
19	1	670-10469	Information Placard, Low Amp Fuse Replacement
20	1	670-10568	Information Placard, Manual Raise/Lower Switch
21	1	670-10471	Information Placard, 200 Amp Fuse Replacement

Placards