

CL Challenger Lifts

Installation, Operation & Maintenance Manual Four Post Surface Mounted Lift

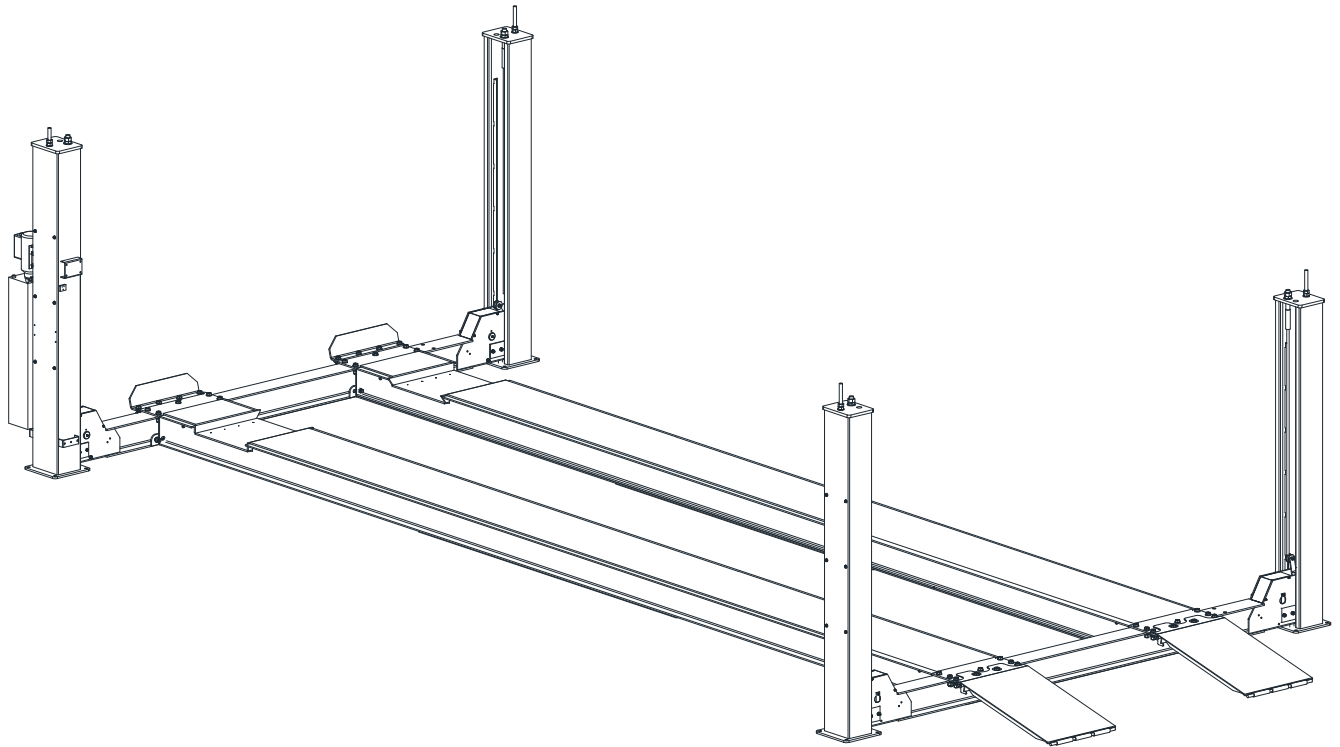

Model 4030

(30,000 lb Capacity)

2311 South Park Rd, Louisville, Kentucky 40219

Email: sales@challengerlifts.com Web site: www.challengerlifts.com

Office 800-648-5438 / 502-625-0700 Fax 502-587-1933

IMPORTANT: READ THIS MANUAL COMPLETELY BEFORE
INSTALLING or OPERATING LIFT

GENERAL SPECIFICATIONS

MODEL: 4030[E OR X] [A OR F] [O OR X]

[LENGTH] [ALIGN OR FLAT DECK] [OPEN OR CLOSED FRONT]

SPECIFICATIONS	4030SFX	4030EFX	4030XFX	4030SAX	4030EAX	4030XAX
A Length Overall	308"	344"	380"	308"	344"	380"
B Width Overall	172.75"					
C Inside Columns	152"					
D Between Columns	246"	282.5"	318.5"	246.5"	282.5"	318.5"
E Height of Columns	92.25"					
F Height of Runways to Bottom of Column	10"					
G Width of Runways	24"					
H Width Between Runways	46" & 52"					
I Maximum Wheelbase *	244.5"	281"	317"	244.5"	281"	317"
J Rise Height	71.75"					
K Max. 2 Wheel Alignment	N/A	N/A	N/A	219.5"	256"	292"
Lifting Capacity (Hydraulic Pressure at Cap.)	30,000 lbs. (2190 psi)					
Air Supply Required	90-120 psi Clean & Dry					
Motor	3HP					
Voltage (Single Phase Std.)	230v					
Rise Time	126 Seconds (approximate)					
Min. Recommended Bay Size	28' x 17'	31' x 17'	34' x 17'	28' x 17'	31' x 17'	34' x 17'

* Maximum wheelbase is based on a tire diameter of 30"

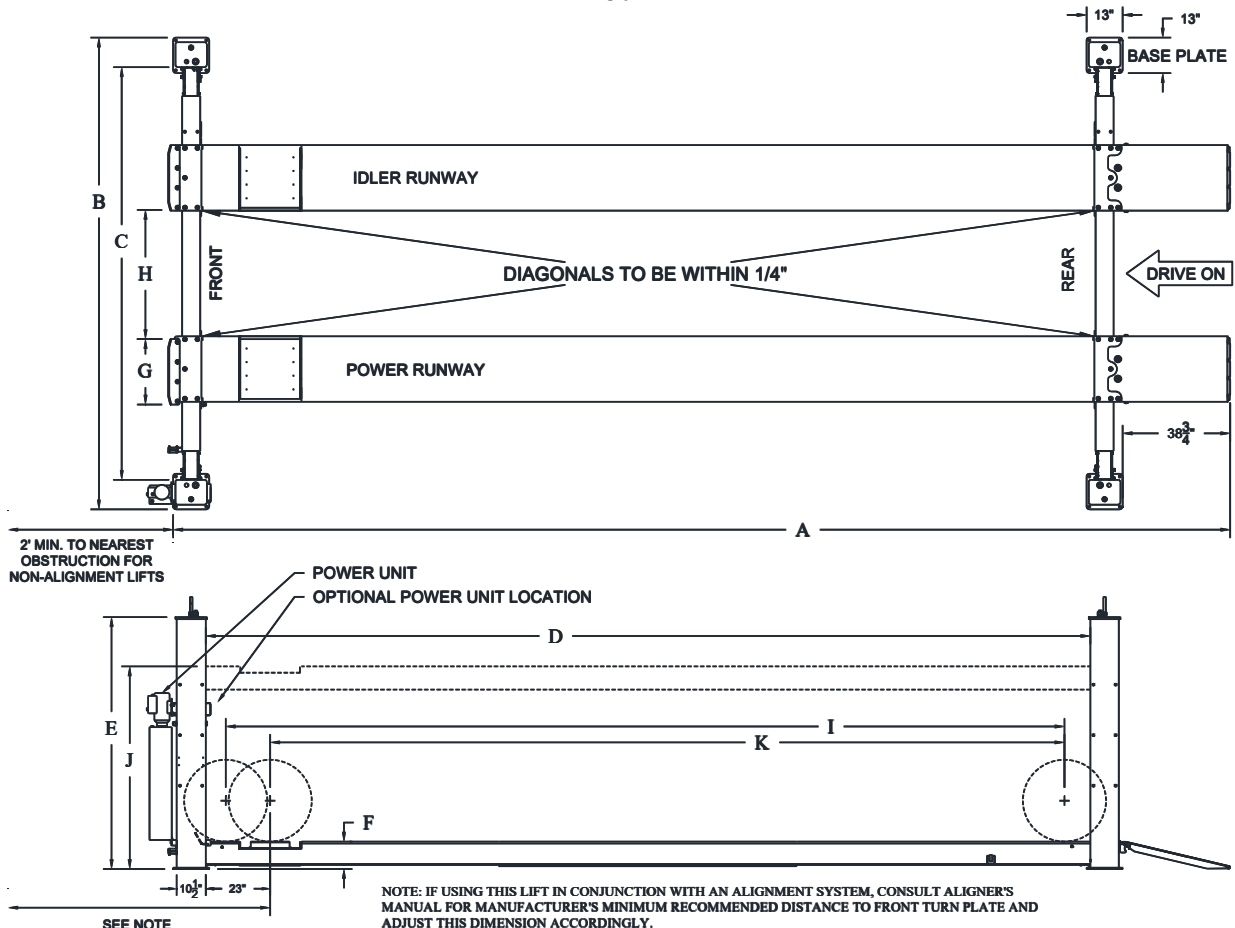

Fig 1 – General Specifications and Service Bay Layout

VERTICAL CLEARANCE

Check the height of the area where the lift is to be installed. Clearance should be calculated based on the full raised height of the lift.



WARNING Failure by purchaser to provide adequate clearance could result in unsatisfactory lift performance, property damage, or personal injury.

FLOORING

Be certain you have the proper concrete floor to properly handle the loaded lift. Floor should be in generally good condition with no large cracks, spalling or deterioration.

Minimum requirements for concrete are 4-inches minimum depth, with steel reinforcement, 3500 psi, cured for 28 days per local commercial practice. This lift is designed to accommodate a 3-inch total variation in elevation at the base of the four posts. Floor should be level within 1/2 inch from side-to-side and 2 1/2 front-to-rear to avoid special shimming. No anchors should be installed within 8 inches of any crack, edge, or expansion joint. If these conditions cannot be met, a pad may be poured to accommodate the lift.

Check with local building inspectors and/or permits office for any special instructions or approvals required for your installation.

A qualified person should be consulted to address seismic loads and other local or state requirements.



WARNING Failure by purchaser to provide the recommended mounting surface could result in unsatisfactory lift performance, property damage, or personal injury.

LOCATION

This lift has been evaluated for indoor use only with an operating ambient temp. range of 5 – 40°C (41-104°F)

ELECTRICAL REQUIREMENTS

For lift installation and operation, it is necessary to have a dedicated circuit with circuit breaker or time delay fuse. Refer to wiring diagram for circuit sizing.

AIR REQUIREMENTS

This lift is equipped with an air operated lock release system. **The air supplied to the lift must be clean, dry, lubricated, and regulated to 90-120 psi, FRL (Filter/Regulator/Lubricator).** The FRL must be within 30 feet of lift. **Failure to provide clean, dry, lubricated, and pressure regulated air will void warranty on pneumatic components.**

SAFETY NOTICES AND DECALS

For your safety, and the safety of others, read and understand all of the safety notices and decals included here.

READ ENTIRE MANUAL BEFORE ASSEMBLING, INSTALLING, OPERATING, OR SERVICING THIS EQUIPMENT.

PROPER MAINTENANCE AND INSPECTION IS NECESSARY FOR SAFE OPERATION.

DO NOT OPERATE A DAMAGED LIFT.

Safety decals similar to those shown here are found on a properly installed lift. Be sure that all safety decals have been correctly installed on the Power Unit reservoir. Verify that all authorized operators know the location of these decals and fully understand their meaning. Replace worn, faded, or damaged decals promptly.



WARNING Do not attempt to raise a vehicle on the lift until the lift has been correctly installed and adjusted as described in this manual.

SAFETY INSTRUCTIONS If attachments, accessories or configuration modifying components that are located in the load path, affect operation of the lift, affect the lift electrical listing or affect intended vehicle accommodation are used on this lift and, if they are not certified for use on this lift, then the certification of this lift shall become null and void. Contact the participant for information pertaining to certified attachments, accessories or configuration modifying components.

www.autolift.org ©2007 by ALI, Inc. ALI / WLSIA01

 SAFETY INSTRUCTIONS Read operating and safety manuals before using lift.	 SAFETY INSTRUCTIONS Proper maintenance and inspection is necessary for safe operation.	 WARNING Clear area if vehicle is in danger of falling.	 WARNING Remain clear of lift when raising or lowering vehicle.
 SAFETY INSTRUCTIONS Do not operate a damaged lift.	The messages and pictographs shown are generic in nature and are meant to generally represent hazards common to all automotive lifts regardless of specific style. Funding for the development and validation of these labels was provided by the Automotive Lift Institute, PO Box 33116 Indianapolis, FL 32903. They are protected by copyright. Set of labels may be obtained from ALI or its member companies. © 1992 by ALI, Inc. ALI/WLS00a	 WARNING Keep clear of pinch points when lift is moving.	 WARNING Keep feet clear of lift while lowering.
 CAUTION Lift to be used by trained operator ONLY.	 CAUTION Authorized personnel only in lift area.	 WARNING Do not override self-closing lift controls.	 WARNING Chock wheel to prevent vehicle movement.
The messages and pictographs shown are generic in nature and are meant to generally represent hazards common to all automotive lifts regardless of specific style. Funding for the development and validation of these labels was provided by the Automotive Lift Institute, PO Box 33116 Indianapolis, FL 32903. They are protected by copyright. Set of labels may be obtained from ALI or its member companies. © 1992 by ALI, Inc. ALI/WLS00a		The messages and pictographs shown are generic in nature and are meant to generally represent hazards common to all automotive lifts regardless of specific style. Funding for the development and validation of these labels was provided by the Automotive Lift Institute, PO Box 33116 Indianapolis, FL 32903. They are protected by copyright. Set of labels may be obtained from ALI or its member companies. © 1992 by ALI, Inc. ALI/WLS00b	

Receiving

The shipment should be thoroughly inspected as soon as it is received. The signed bill of lading is acknowledgement by the carrier of receipt in good condition of shipment covered by our invoice.

If any of the goods called for on this bill of lading are shorted or damaged, do not accept them until the carrier makes a notation on the freight bill of the shorted or damaged goods. Do this for your own protection.

NOTIFY **Challenger Lifts** AT ONCE if any hidden loss or damage is discovered after receipt.

IT IS DIFFICULT TO COLLECT FOR LOSS OR DAMAGE AFTER YOU HAVE GIVEN THE CARRIER A CLEAR RECEIPT.

File your claim with **Challenger Lifts** promptly. Support your claim with copies of the bill of lading, freight bill, and photographs, if available.

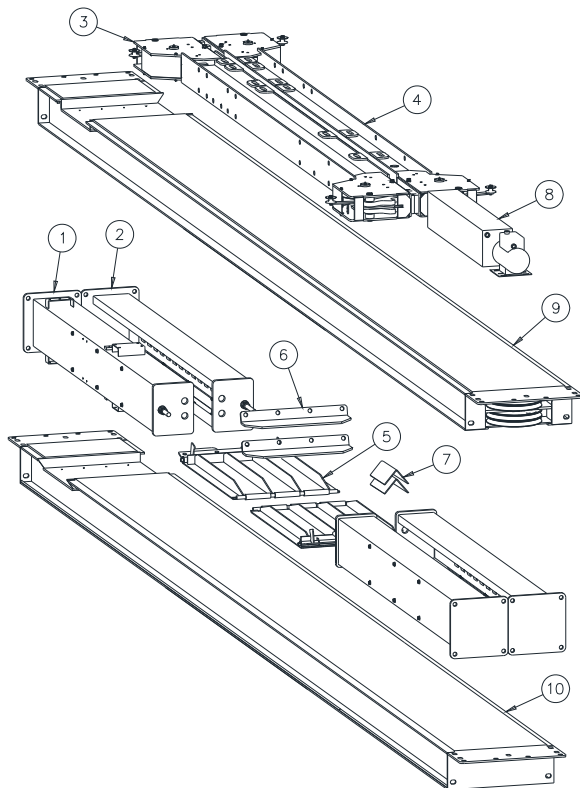

Fig 2 – Package Components

Edition of Standards Referenced

Where any ANSI standard is referenced within this manual, the most recent edition approved by the American National Standards Institute, Inc. shall apply.

Component Packing List

ITEM #	PART #	QTY/LIFT	DESCRIPTION
1	9430-2000	1	POWER COLUMN ASSEMBLY
2	9430-1000	3	IDLER COLUMN ASSEMBLY
3	9430-4000	1	REAR CROSSBEAM
4	9430-3000	1	FRONT CROSSBEAM
5	9430-0306	2	RAMP ASSEMBLY
6	7430-0367	2	FRONT WHEEL STOP
7	7430-0506	2	WHEEL CHOCK
8	AB-100157	1	POWER UNIT
9	9430-0308	1	POWER RUNWAY ASSEMBLY
10	8430-0334	1	IDLE RUNWAY ASSEMBLY
11	8430-0334	1	IDLE RUNWAY ASSEMBLY

INSTALLATION

SAFETY REQUIREMENTS FOR INSTALLATION AND SERVICE

Refer to ANSI/ALI ALIS (current edition)

IMPORTANT: Always wear safety glasses while installing lift.

TOOLS (MINIMUM REQUIRED)

- a. Tape measure, 50ft.
- b. Chalk line.
- c. 4ft level.
- d. 2 adjustable wrenches to 1-5/8".
- e. Standard open end wrenches 3/8", 7/16", 1/2", 9/16", 5/8", (2) 11/16", 3/4", 15/16", 1-5/16".
- f. 3.5 hex key wrench.
- g. Box knife.
- h. Thread locking compound non-permanent.
- i. Thread tape sealant (for air line).
- j. Needle nose pliers.
- k. Hammer drill with 3/4" diameter carbide tipped bits.
- l. 2lb hammer.
- m. Torque wrench: 110 foot-pounds minimum with 1 1/8" socket.
- n. 8 ft. Step ladder.
- o. Blocking – (4) 4x4x30".
- p. Transit for leveling alignment lift.
- q. 1 Vice grip.

LAYOUT

- 1) Lay out the service bay according to the architect's plans or owners instructions (**see Fig 1**). Be certain that the proper conditions exist, see page 3.
- 2) Unpack lift. Remove all packaging from Power Runway (power runway has four cable sheaves at rear end and two at front). Make sure the cables are in the proper sheaves at both ends of the runway, **Figs 3 & 4**.

Model 4030
Installation, Operation and Maintenance

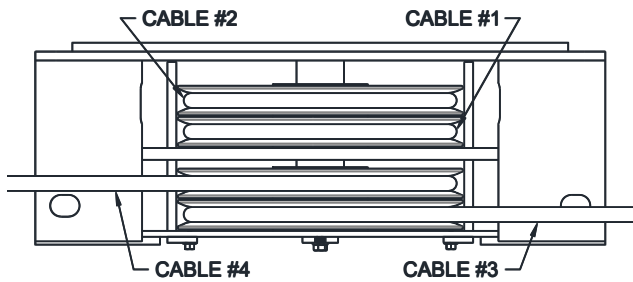

Fig 3 – Power Runway 4-Stack (rear view)

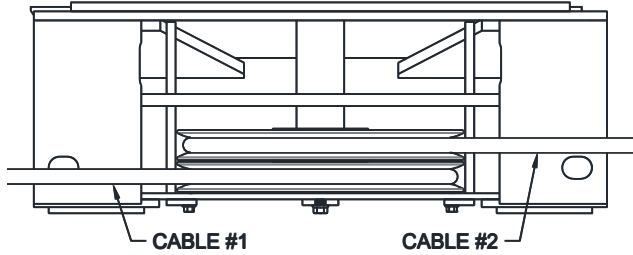

Fig 4 – Power Runway 2-Stack (front view)

- 3) Position runways on blocking, see **Fig 5**, per layout lines established in step 1. Use four 30" long 4x4's spanning the width of the runway. Cables #3 and #4 should be extending out from the rear of the power runway and cables #1 and #2 from the front of the power runway, **Fig 5**.
- 4) Position the front and rear cross beams, **Fig 5**.
- 5) Feed Cable #3 through the cross beam, **Figs 5 & 6**. Note: The Slack Cable Latch springs must be removed, but the Cross Beam Sheaves do not. Feed cable thru above air cylinder and then on to the sheave, see **Fig 6**.
- 6) Repeat for remaining cables ensuring that cable #4 is on top of cable #3 and #2 is on top of #1.

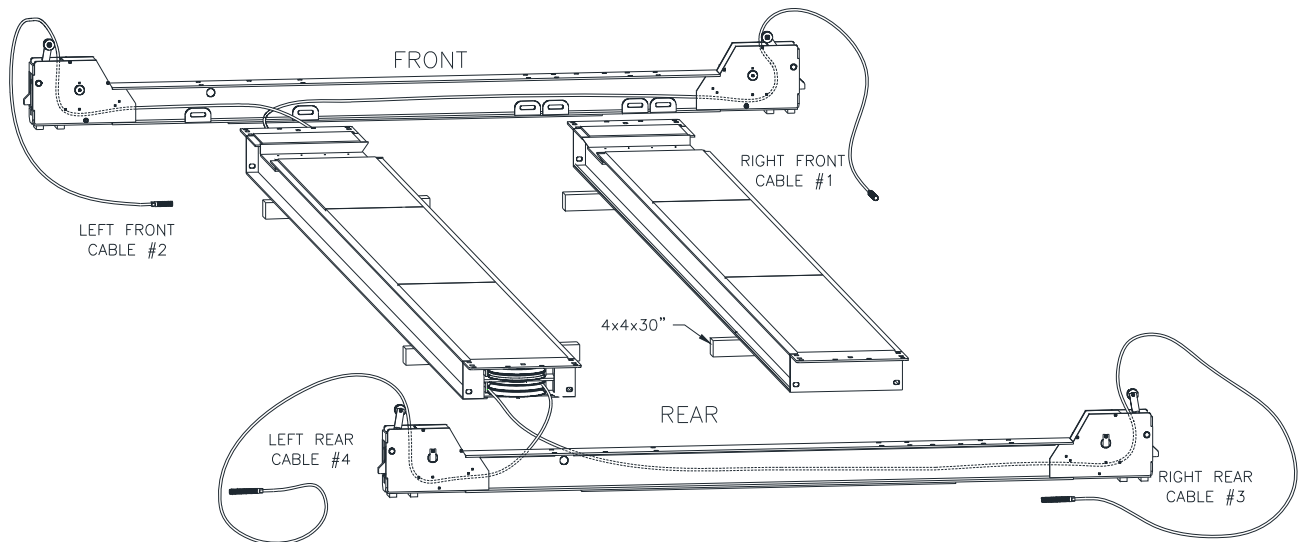

Fig 5 – Runway Layout

Model 4030
Installation, Operation and Maintenance

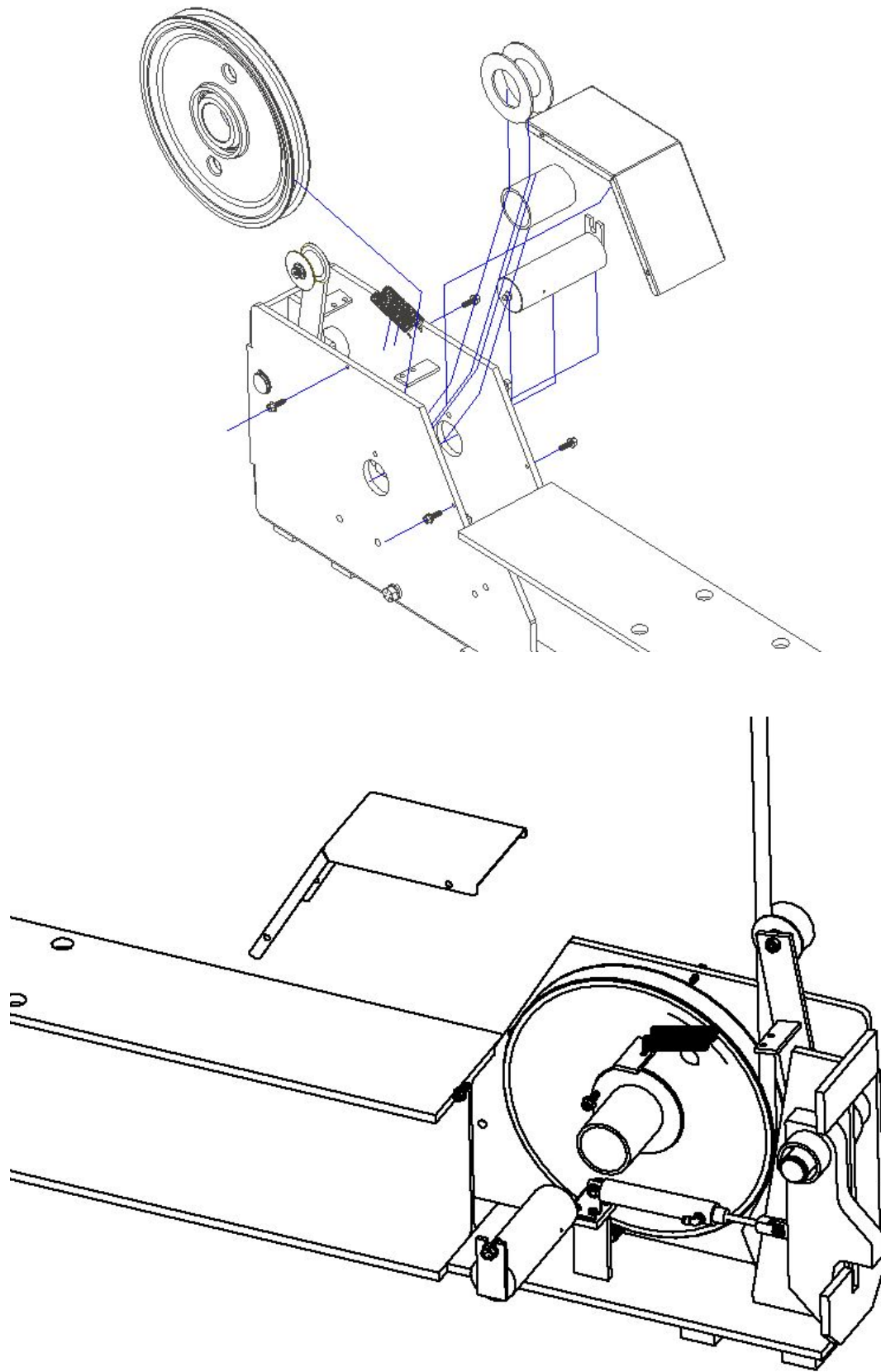

Fig 6 - Cross Rail Assembly

- 7) Attach both cross beams to the runways (**Fig. 4**) using 3/4"-16, 2.5" Length Steel Hex Cap Screws, ZC-PLTD, a 3/4" screw size washer on the bolt head side, and nut side. secure with a 3/4"-16 GRADE 8 STEEL NYLON-INSERT LOCKNUT. Position the power runway on top of the cross rail and align the slots with the holes. The idler runway can be installed using the outer or inner sets of cross beam holes, see "Width Between Runways" dimension in Fig. 1. Do not torque bolts yet.
- 8) Check the layout of the lift in the bay. (**This is the last opportunity to reposition the lift.**) Adjust the position of the runways so the distance from power side jack rail to idler side jack rail is the same at the front and the rear and the diagonal measurements from the front tip of one rail to rear tip of the opposite rail are within 1/4", **Fig 7**.

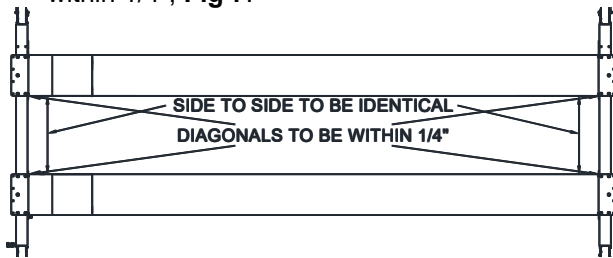

Fig 7 – Final Runway Positioning

- 9) Center cross beam bolts with slots in runway and tighten. (Be careful not to move runways.)
- 10) Bolt the runways as shown in Figure I. Repeat for all 8x places. and Bolt the Ramps as shown on Figure J

COLUMNS

- 11) Stand up a column assembly near each corner of the lift (column with power unit bracket goes at the 2-sheave-stack corner) {see page 2 Measure from the bottom of the ladder, to the top of the column base plate, Adjust the ladder so the bottom of the ladder, to the top of the column base plate is 12 inches.
- 12) Slide power side column onto cross beam until the 1/2"-13 threaded holes in the side of the beam are just exposed. Position slide blocks as shown in **Fig 8** and **Fig 9** and attach with 1/2"-13, 0.75" Length steel cap screw, ZC-PLTD, GR-8 bolts (**apply thread nonpermanent locking compound before installing**).

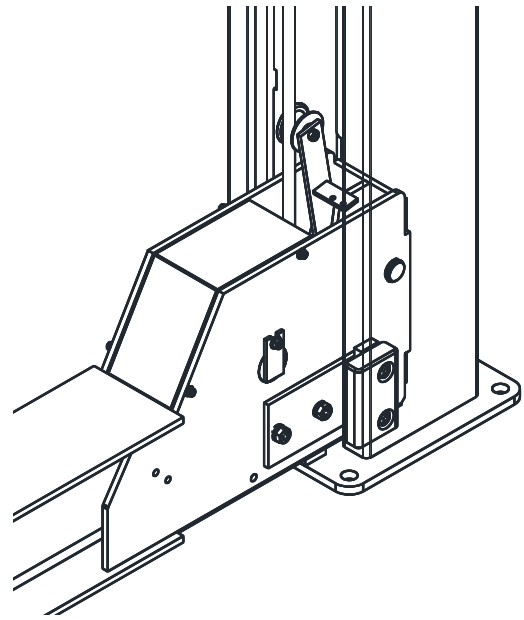

Fig 8 – Slide Block Installation

- 13) Push the column against the slide blocks, **Fig 9**. Measure from the column to the edge of the rub block bracket. the dimension should be 4-5/8\"".

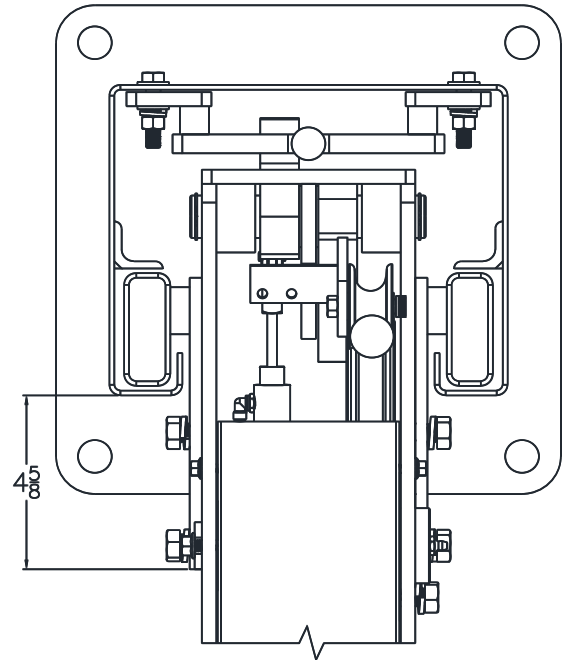

Fig 9 – Column Positioning

- 14) Repeat for remaining three columns.

ANCHORING

- 15) The anchor bolts must be installed at least 8" from any crack, edge, or expansion joint. Also, at least 16" from any other lifts hole.
- 16) Use a concrete hammer drill with a 3/4-inch carbide bit. Tip diameter should conform to ANSI Standard B212.15 (.775 to .787). Do not use excessively worn bits or bits which have been incorrectly sharpened. A core bit may be necessary if an obstruction is encountered. **Never substitute with shorter anchor.**
- 17) Drill the anchor holes using the base plate as a template. Drill through the floor if possible or to a depth of 5 inches minimum.
- 18) Vacuum dust from the hole for proper holding power.
- 19) Shim columns to plumb using the shims provided or steel washers. DO NOT shim more than 1/2" at any given point. Use a level no less than 24" in length to vertically plumb columns.
- 20) Assemble washer and nut to anchor with nut just below impact section of bolt. Drive anchor into hole until nut and washer contact base. Tighten anchor bolts and recheck column for plumb. Re-shim as required.
- 21) Torque to 110 foot-pounds to set anchors.

NOTE: Level bubble should not only be between the lines; the bubble should be centered between the lines. If the provided shims do not allow sufficient centering of the bubble, it is best to lean the rear columns in the direction toward each other and the front columns in the direction toward each other.

- 22) Install the four cable ends with one flat washer, one load nut, and one jam nut. See Item's 21, 22, & 23 on page 15. Pull the cables, on until the tension of the cables overpowers the springs on the cross beam (disengages the locks). The Slack device pulley mechanism should be vertical, as shown on figure 5. The cables need to be inserted on the top hole of the column. Ensure the cable is aligned with the cross beam sheaves. (Do not put tension on the slack device if it is setting on the locks to avoid damage).
- 23) Install the power unit and the air button valve assembly on the power column, **Fig 10**.

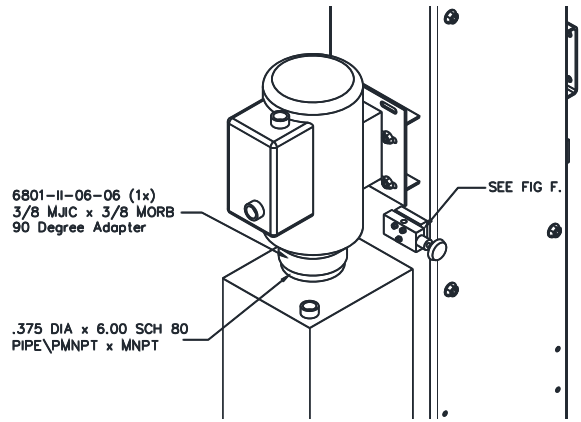

Fig 10 – Air Button & Power Unit Mounting

- 24) Install O-Ring end of 90-degree hydraulic elbow & pipe (6801-LL-06-06 ELBOW {pressure port} & 4550K152 0.375 DIA X 1.50 SCH 80 PIPE MNPT X MNPT) (May need to remove plug on the power unit return port to install part 4550K152) to power unit. The hydraulic hose is pre-installed to the hydraulic cylinder and secured inside the runway. Pull loose end out through the gap between runway and cable retaining bar. (Figure G.) Pull hoses through the hole on the cross beams. Attach a 2500-06-06, 90 degree fittings on each hose, then connect hose 1034-0003 on each of the 90-degree fitting done previously. Connect the hose line closest to the cylinder rod (The longest hose {PRESSURE LINE}) to the 6801-LL-06-06 fitting on the power unit. Connect 2502-06-06 3/8 MJIC X 3/8 FNPT 90 ELL to the pipe on the power unit 4550K162. Connect the hose line closest to the cylinder clevis (shortest hose {RETURN LINE}) to the elbow (2502-06-06) previously connected to the pipe **Do Not Use Teflon Tape or Pipe Dope** on fittings.
- 25) Have a certified electrician connect the power unit to a suitable electrical power source as shown in **Fig 15**.

Wiring Diagram

* EACH LIFT SHOULD HAVE A DEDICATED CIRCUIT WITH A DOUBLE POLE (THREE POLE FOR 3 PHASE) BREAKER OR TIME DELAY FUSE SIZED ACCORDING TO THE FOLLOWING CHART.

	1 ϕ 208-240V	3 ϕ 208V	3 ϕ 220-240V	3 ϕ 440-480V
3Hp	30amp	15amp	15amp	5amp

* WIRING MUST COMPLY WITH ALL LOCAL ELECTRICAL CODES.

* ELECTRICAL CODE REQUIRES A SERVICE DISCONNECT FOR THIS DEVICE. WE SUGGEST THIS SERVICE DISCONNECT BE LOCATED NEAR THE POINT OF OPERATION.

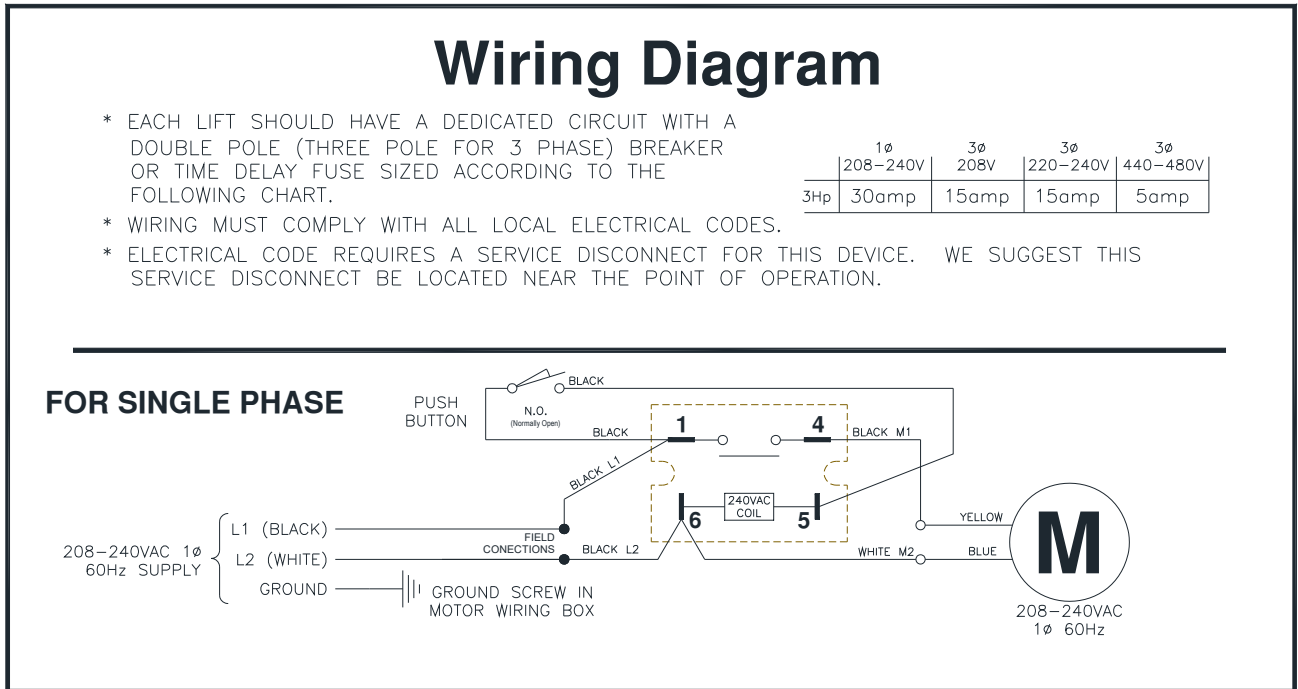

Fig 15 – Electrical Wiring Diagram

- 26) **BE CERTAIN ALL FITTINGS AND CONNECTIONS ARE TIGHT. IT IS THE INSTALLERS RESPONSIBILITY TO INSURE SYSTEM IS LEAK-FREE.** Fill the Power Unit with 6.3 gallons of clean 10wt anti-foam anti-rust hydraulic oil or Dexron III ATF. **Do NOT USE OILS WITH DETERGENTS.**
- 27) Energize the power unit and raise the lift approximately 1-ft off the ground and look underneath the power runway to verify that the cable lugs are resting firmly against the cylinder pull bar.
- 28) For flat deck style runways, level the runways and crossbeams using a 4 ft. level. With the lift resting in its locks, find the highest corner and adjust the other three column ladder bars until the runways are level front-to-rear and side-to-side. Tighten jam nut against bottom side of each column top plate. For alignment style runways, use a transit for leveling runways placing the target in the center of the turn plate (with lift lowered into locks, adjusting the lock ladders as needed). Refer to alignment equipment for leveling tolerance.
- 29) Install 5/32" air line from air valve assembly thru opening in runway to Tee. **Fig 11 & F**
- 30) Route power side front and rear cross beam air lines through power runway (See Figure G) to Tee with 5/32" airline provided. Use welded rings inside the power runway to secure air lines. Insert 5/32" air line through the tubing in front of the crossbeams **Fig 12**
- 31) See **Figure F**. Connect 6534K46 to an air supply. **Air supply must be clean, dry, lubricated, and regulated to 90-120 psi.** The FRL, must be within 30 feet of valve. **Failure to provide clean, dry, lubricated, and pressure regulated air will void warranty on pneumatic components.**
- 32) While hanging on the cables energize air valve assembly and insure that all air cylinders are working properly.
- 33) Adjust cables until all four locks are synchronized when lift is raised. Tighten cable jam nuts against adjustment nuts.



Fig 11 – Lock Release Air Line Routing

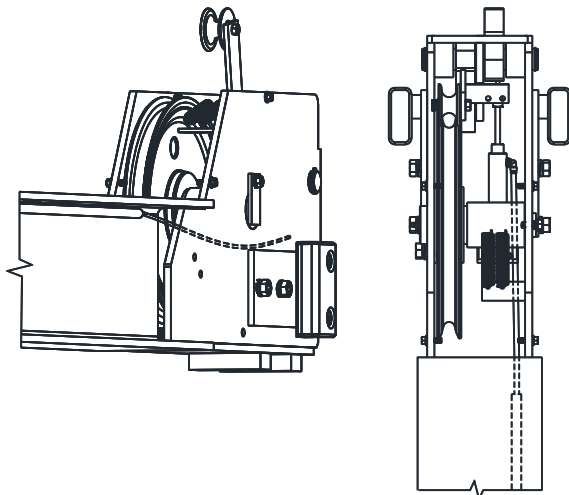

Fig 12 – 5/32 Air Line Connection

- 34) Clamp the airlines and hydraulic hoses with bracket, as shown. See Figure H. Add Abrasion-Resistant Sleeve. (55545K86) to protect the hoses and airline.
- 35) Install Grease Fittings. 6 fittings in total. 2 on each cross beam pins. and 2 fittings on the runway pins. See figure C & D
- 36) Raise and lower lift several times to bleed hydraulic cylinder. Hydraulic cylinder is self-bleeding. Lower lift and check fluid level in reservoir. Add fluid as needed.
- 37) Run lift to full rise and continue running motor approximately 5 more seconds. Check hydraulic hose and connections for leaks. Re-tighten fitting if leaking.
- 38) Raise lift approximately half way. Slowly jog power unit until you hear one of the locks engage. Adjust locking ladder until it just barely raises the crossbeam end. Back off 1/2 turn. Repeat for each column.

COLUMN DECAL PLACEMENT

- 39) Center the decal on the front drivers side column and rear passenger side column.
- 40) Apply decal 4" from top of columns, **Fig 13**.

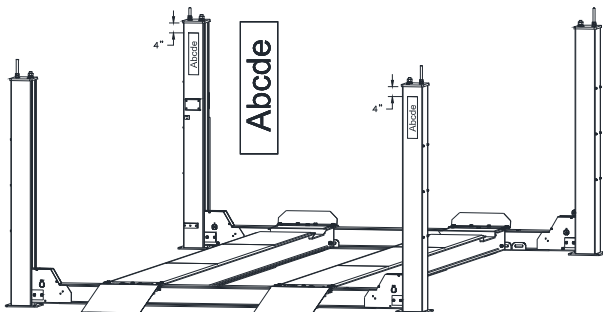

Fig 13 – Decal Placement

ALIGNMENT RUNWAYS

- 41) Lower lift and raise to check for lock engagement. The locks should engage simultaneously (clicking noise). Re-adjust cables as needed to synchronize locks.
- 42) Position Front Turn Plates (SOLD SEPARATELY) and install TURN TABLE STOPS (ITEM 1 PART NUMBER ALIG-430-029-XX) to runway using (8, ITEM 2) #10-24 x 0.75" Socket Head Cap Screws. Ensure that the Turn Plates will slide freely and tighten Guide Bars. Reference **Fig 14** and Fig L

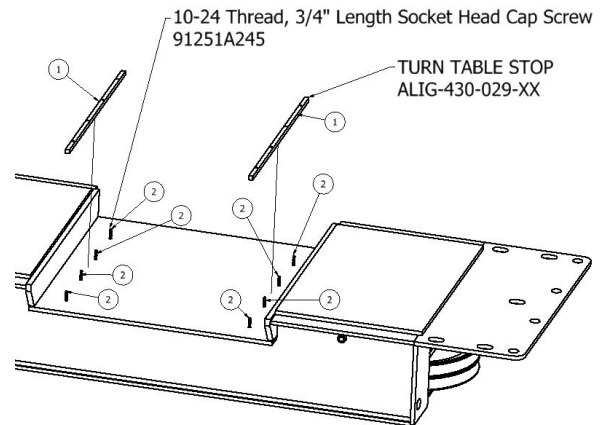

Fig 14 – Alignment Turn Plate Installation

FINAL CHECKOUT PROCEDURE

- 43) Demonstrate the operation of the lift to the owner/operator/employer using a typical vehicle and review correct and safe lifting procedures using the **Lifting It Right** booklet as a guide.
- 44) Return all provided literature (including this manual) to the literature pack envelope and deliver the envelope to the owner/operator/employer.
- 45) Complete the online warranty registration (refer to the included warranty statement).

OPERATION PROCEDURE

SAFETY NOTICES AND DECALS

This product is furnished with graphic safety warning labels, which are reproduced on page 3 of these instructions. Do not remove or deface these warning labels or allow them to be removed or defaced. For your safety, and the safety of others, read and understand all of the safety notices and decals included.

OWNER/EMPLOYER RESPONSIBILITIES

This lift has been designed and constructed according to ANSI/ALI ALCTV standard. The standard applies to lift manufacturers, as well as to owners and employers. The owner/employer's responsibilities as prescribed by ANSI/ALI ALOIM, are summarized below. For exact wording refer to the actual standard provided with this manual in the literature pack.

The Owner/Employer shall ensure that lift operators are qualified and that they are trained in the safe use and operation of the lift using the manufacturer's operating instructions; ALI/SM, *ALI Lifting it Right safety manual*; ALI/ST, *ALI Safety Tips card*; ANSI/ALI ALOIM, *American National Standard for Automotive Lifts-Safety Requirements for Operation, Inspection and Maintenance*; ALI/WL Series, *ALI Uniform Warning Label Decals/Placards*; and in case of frame engaging lifts, ALI/LP-GUIDE, *Vehicle Lifting Points/Quick Reference Guide for Frame Engaging Lifts*.

The Owner/Employer shall establish procedures to periodically inspect the lift in accordance with the lift manufacturer's instructions or ANSI/ALI ALOIM, *American National Standard for Automotive Lifts-Safety Requirements for Operation, Inspection and Maintenance*; and the employer shall ensure that the lift inspectors are qualified and that they are adequately trained in the inspection of the lift.

The Owner/Employer shall establish procedures to periodically maintain the lift in accordance with the lift manufacturer's instructions or ANSI/ALI ALOIM, *American National Standard for Automotive Lifts-Safety Requirements for Operation, Inspection and Maintenance*; and the employer shall ensure that the lift maintenance personnel are qualified and that they are adequately trained in the maintenance of the lift.

The Owner/Employer shall maintain the periodic inspection and maintenance records recommended by the manufacturer or ANSI/ALI ALOIM, *American National Standard for Automotive Lifts-Safety Requirements for Operation, Inspection and Maintenance*.

The Owner/Employer shall display the lift manufacturer's operating instructions; ALI/SM, *ALI Lifting it Right safety manual*; ALI/ST, *ALI Safety Tips card*; ANSI/ALI ALOIM, *American National Standard for Automotive Lifts-Safety Requirements for Operation, Inspection and*

Maintenance; and in the case of frame engaging lift, ALI/LP-GUIDE, *Vehicle Lifting Points/Quick Reference Guide for Frame Engaging Lifts*; in a conspicuous location in the lift area convenient to the operator.

IMPORTANT SAFETY INSTRUCTIONS

When using your garage equipment, basic safety precautions should always be followed, including the following:

1. Read all instructions.
2. Care must be taken as burns can occur from touching hot parts.
3. To reduce the risk of fire, do not operate equipment in the vicinity of open containers of flammable liquids (gasoline).
4. Keep hair, loose clothing, fingers, and all parts of body away from moving parts.
5. Use only as described in this manual. Use only manufacturer's recommended attachments.
6. ALWAYS WEAR SAFETY GLASSES. Everyday eyeglasses only have impact resistant lenses, they are not safety glasses.

SAVE THESE INSTRUCTIONS

LIFTING A VEHICLE

Drive vehicle onto lift. Set parking brake and/or use wheel chocks that are provided with lift.

When the vehicle has reached the desired working height, release the power pack button, and lower the vehicle until the safety locks are engaged. The vehicle should remain level when all locks are engaged. If one side engages and the other continues to descend, stop lowering the vehicle, raise it several inches, and try again to engage locks.

IMPORTANT, before walking under the lift insure that all locks are properly engaged.

It is not safe to work under the vehicle unless all locks are engaged, and the vehicle is level.

LOWERING A VEHICLE

Insure that the area under the vehicle is clear of personnel and tools.

Raise the vehicle until locks are free.

Disengage the locks by depressing the palm button and holding it.

Lower the vehicle by depressing the lowering valve handle. Watch lift to insure that the lift is lowering evenly. If not, raise lift and check all locks to insure they are disengaged before trying to lower lift again.

Continue to lower the vehicle until the crossbeams stop against the base plate. It is important to fully lower the lift to release hydraulic pressure on the system.

LOSS OF POWER

If for any reason, the lift will not raise off the locks or the locks will not retract, consult factory authorized personnel.

DO NOT OVERRIDE ANY SAFETY FEATURE IN AN ATTEMPT TO LOWER THE LIFT.

JACK NO GO ZONE

DO NOT PLACE ROLLING JACKS WITHIN 50 INCHES FROM THE CENTER OF THE RUNWAY.

MAINTENANCE

To avoid personal injury, permit only qualified personnel to perform maintenance on this equipment. Maintenance personnel should follow lockout/tag out instructions per ANSI Z244.1.

The following maintenance points are suggested as the basis of a routine maintenance program. The actual maintenance program should be tailored to the installation and include a record of each planned maintenance activity and repair maintenance activity performed. Refer to the maintenance section of the ANSI/ALI ALOIM booklet (blue book) provided with the lift.

- If lift stops short of full rise or chatters, check fluid level.
- Replace all Safety, Warning or Caution Labels if missing or damaged. (**See *Installation instructions page 3.***)

Daily

- Keep lift components clean. **To keep alignment lifts with rear slip plates working properly use compressed air to blow out any debris from the bearing area.**
- Check for loose or broken parts.
- Check hydraulic system for fluid leaks.
- Check lock release activation.

Weekly

- Check cables and sheaves for wear or damage. Replace as required with genuine Challenger Lifts parts.
- Inspect lock mechanism for proper function.

Monthly

- Torque concrete anchor bolts to 110 ft-lbs.
- Clean and inspect cables and sheaves for wear or damage. Lubricate cables with oil and sheaves with grease.
- Visually inspect concrete floor for cracks and/or spalls within 12" of base plate

IMPORTANT! Failure to keep lift free of corrosive agents and solvents will lead to reduced service life, which could result in property damage and/or personal injury.

If any problems are encountered, contact your local service representative.

Parts Breakdown

Fig A. General Layout

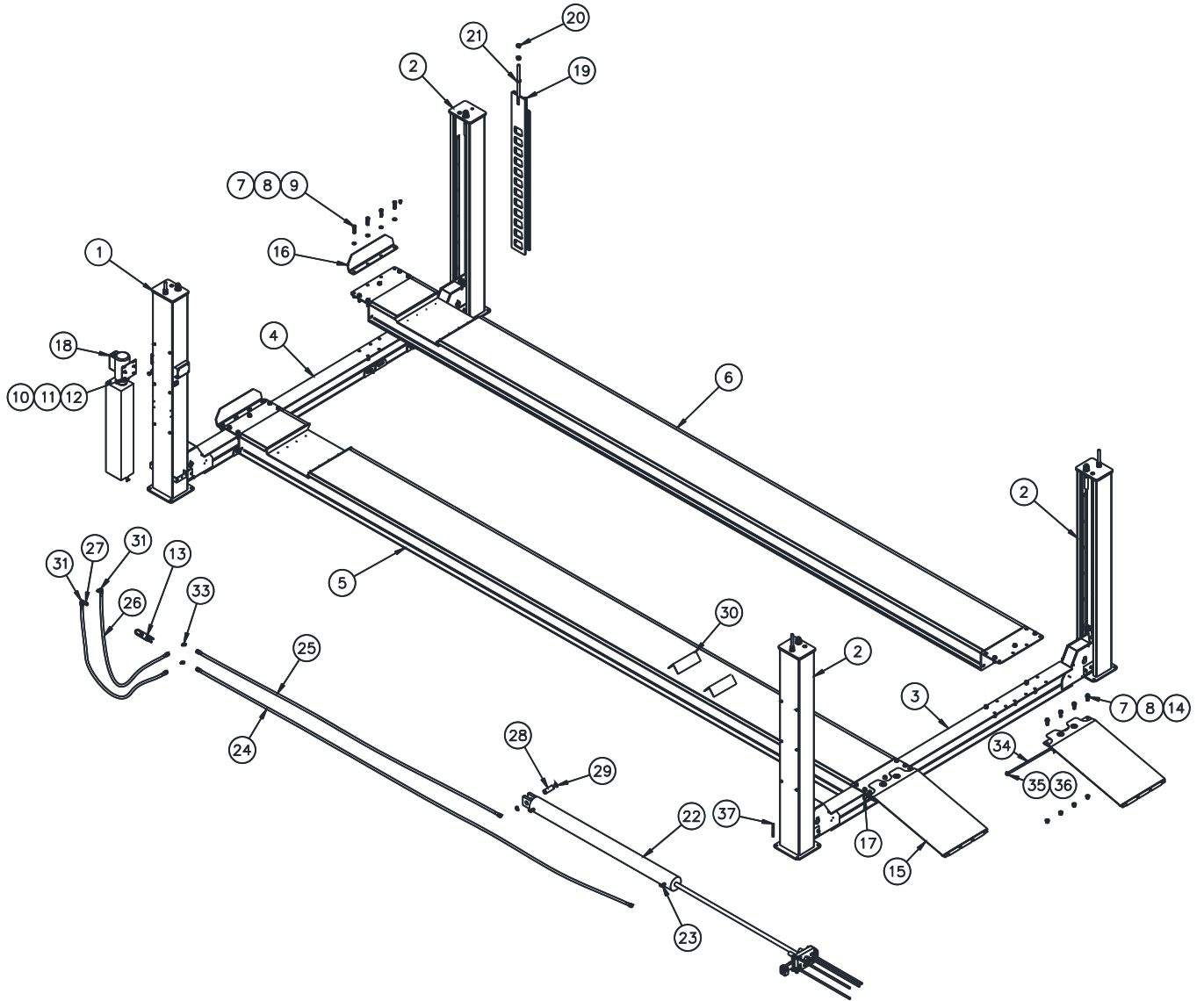

Model 4030
Installation, Operation and Maintenance

ITEM #	PART #	QTY/LIFT	DESCRIPTION
1	9430-2000	1	POWER COLUMN ASSY.
2	9430-1000	3	IDLE COLUMN ASSY.
3	9430-4000	1	REAR CROSSBEAM
4	9430-3000	1	FRONT CROSSBEAM
5	8430-0340	1	POWER RUNWAY WELD (4030SFX)
	8430-0357		POWER RUNWAY WELD (4030EFX)
	8430-0336		POWER RUNWAY WELD (4030XFX)
	8430-0347		POWER RUNWAY WELD (4030SAX)
	8430-0353		POWER RUNWAY WELD (4030EAX)
	8430-0321		POWER RUNWAY WELD (4030XAX)
6	8430-0341	1	IDLE RUNWAY WELD (4030SFX)
	8430-0356		IDLE RUNWAY WELD (4030EFX)
	8430-0337		IDLE RUNWAY WELD (4030XFX)
	8430-0348		IDLE RUNWAY WELD (4030SAX)
	8430-0352		IDLE RUNWAY WELD (4030EAX)
	8430-0343		IDLE RUNWAY WELD (4030XAX)
7	98023A023	88	3/4" SCREW SIZE, ZC WASHER, GR 8
8	97135A285	44	3/4"-16, NYLON LOCKNUT, GR 8
9	92620A874	24	3/4"-16, 2.5" LENGTH HEX CAP SCRW, ZC, GR 8
10	92620A583	5	5/16"-18, 1" LENGTH HEX CAP SCRW, ZC, GR 8
11	90126A030	9	5/16", STEEL FLAT WASHER
12	97135A220	5	5/16"-18, NYLON LOCKNUT, GR 8
13	9430-0302	1	XRAIL HOSE CLAM ASSY
14	92620A872	21	3/4"-16, 2.0" LENGTH, HEX CAP SCRW, ZC, GR 8
15	9430-0306	2	RAMP ASSY,
16	7430-0367	2	FRONT STOP
17	9600K223	2	GROMMET, FITS 1-3/4" HOLE
18	AB-100157	1	POWER UNIT
19	8430-0322	4	LOCK LADDER
20	94895A842	8	7/8"-9 ZC YW-CHROME PLT STEEL HEX NUT, GR8
21	98023A037	4	7/8" CHROME PLT WASHER 1.7" OD, GR 8
22	S618140-1	1	HYDRAULIC CYLINDER
23	50695k184	2	.375 JIC X .375 NPT 90 DEG.
24	1034-0007	1	HYD HOSE- SUPPLY (4030S)
	1034-0005		HYD HOSE- SUPPLY (4030E)
	1034-0002		HYD HOSE- SUPPLY (4030X)
25	1034-0006	1	HYD HOSE- RETURN (4030S)
	1034-0004		HYD HOSE- RETURN (4030E)
	1034-0001		HYD HOSE- RETURN (4030X)
26	1034-0003	2	HYD 97" HOSE- SHORT
27	4550K152	1	3/8" DIA X 1.5" SCH 80 PIPE MNPTXMNPT
28	7430-5003	1	CYLINDER CLEVIS PIN
29	9410A139	2	1 1/2" SHAFT DIAMETER SNAP RING
30	7430-0506	2	WHEEL CHOCKS
31	6801-LL-06-06	1	.37 MJIC X .37 MO-RNG 90
32	2502-06-06	1	3/8 MJIC X 3/8 FNPT 90
33	2500-06-06	2	3/8 JIX X 3/8 JIC 90 DEG FITTING
34	7430-7001	2	RAMP PIN
35	16934	4	5/8" WASHER
36	40126	4	1/8" X 1-1/2" COTTER PIN
37	31058	16	3/4" x 5 1/2" ANCHOR BOLTS

Replace all worn, damaged, or broken parts with parts approved by **Challenger Lifts Inc.** or with parts meeting **Challenger Lifts Inc.** specifications.
Contact your local Challenger Lifts Parts Distributor for pricing and availability.
(Call Challenger Lifts Inc. (502) 625-0700 for the Parts Distributor in your area)

PARTS BREAKDOWN (continued)

Fig B. Cables

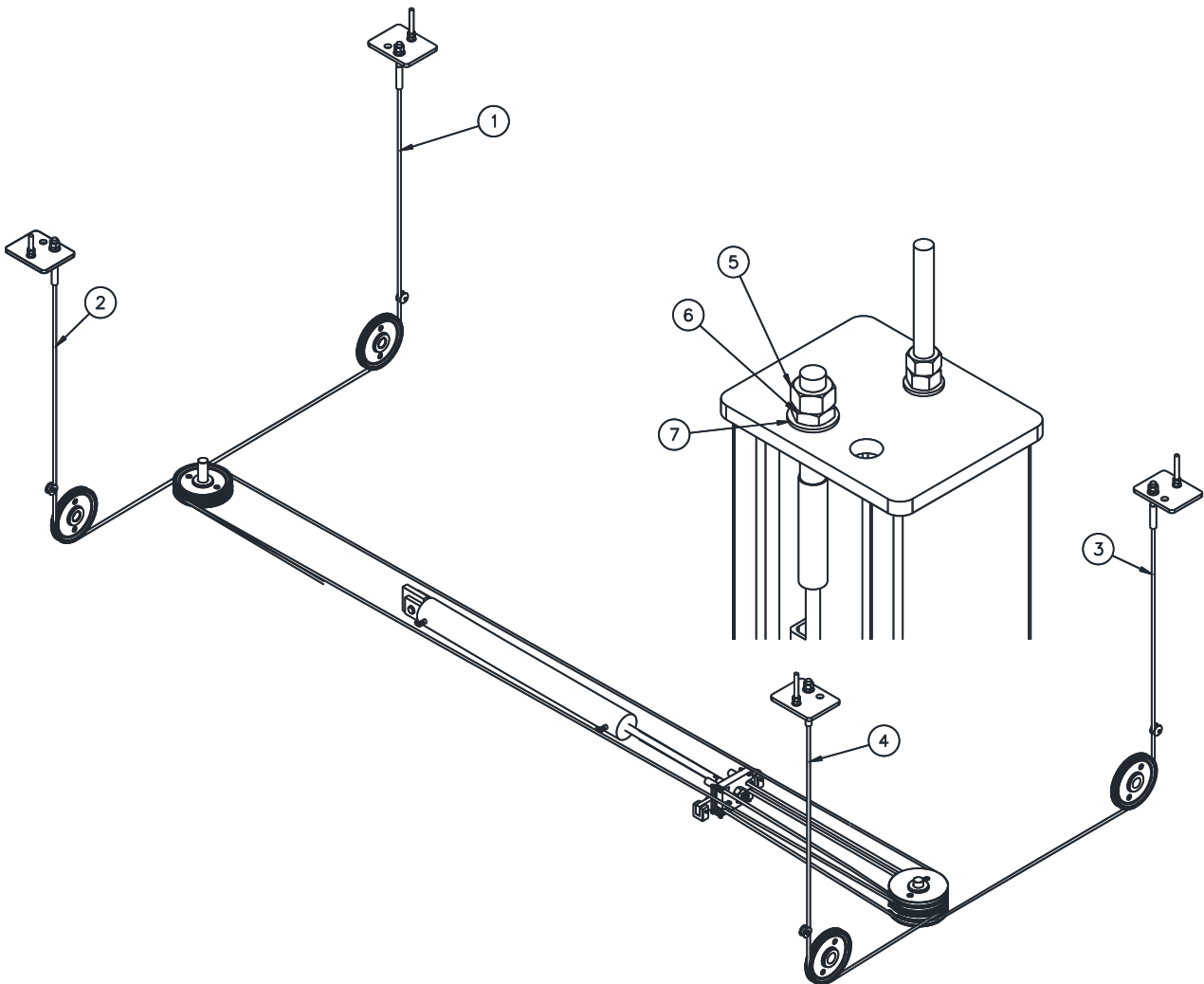

ITEM #	PART #	QTY/LIFT	DESCRIPTION
1	1032-0012	1	CABLE 1, 5/8" (SFX, SAX)
	1032-0016		CABLE 1, 5/8" (EFX, EAX)
	1032-0008		CABLE 1, 5/8" (XFX, XAX)
2	1032-0013	1	CABLE 2, 5/8" (SFX, SAX)
	1032-0017		CABLE 2, 5/8" (EFX, EAX)
	1032-0007		CABLE 2, 5/8" (XFX, XAX)
3	1032-0006	1	CABLE 3, 5/8"
4	1032-0005	1	CABLE 4, 5/8"
5	94895A858	4	1-1/8"-12 HEX NUT, ZC, GR 8
6	93839A858	4	1-1/8"-12 THIN HEX NUT, ZC, GR 8
7	98023A039	4	1-1/8" ID, WASHER, ZC, GR 8

Replace all worn, damaged, or broken parts with parts approved by **Challenger Lifts Inc.** or with parts meeting **Challenger Lifts Inc.** specifications.

Contact your local Challenger Lifts Parts Distributor for pricing and availability.

(Call Challenger Lifts Inc. (502) 625-0700 for the Parts Distributor in your area)

PARTS BREAKDOWN (continued)

Fig C. Runway Sheaves

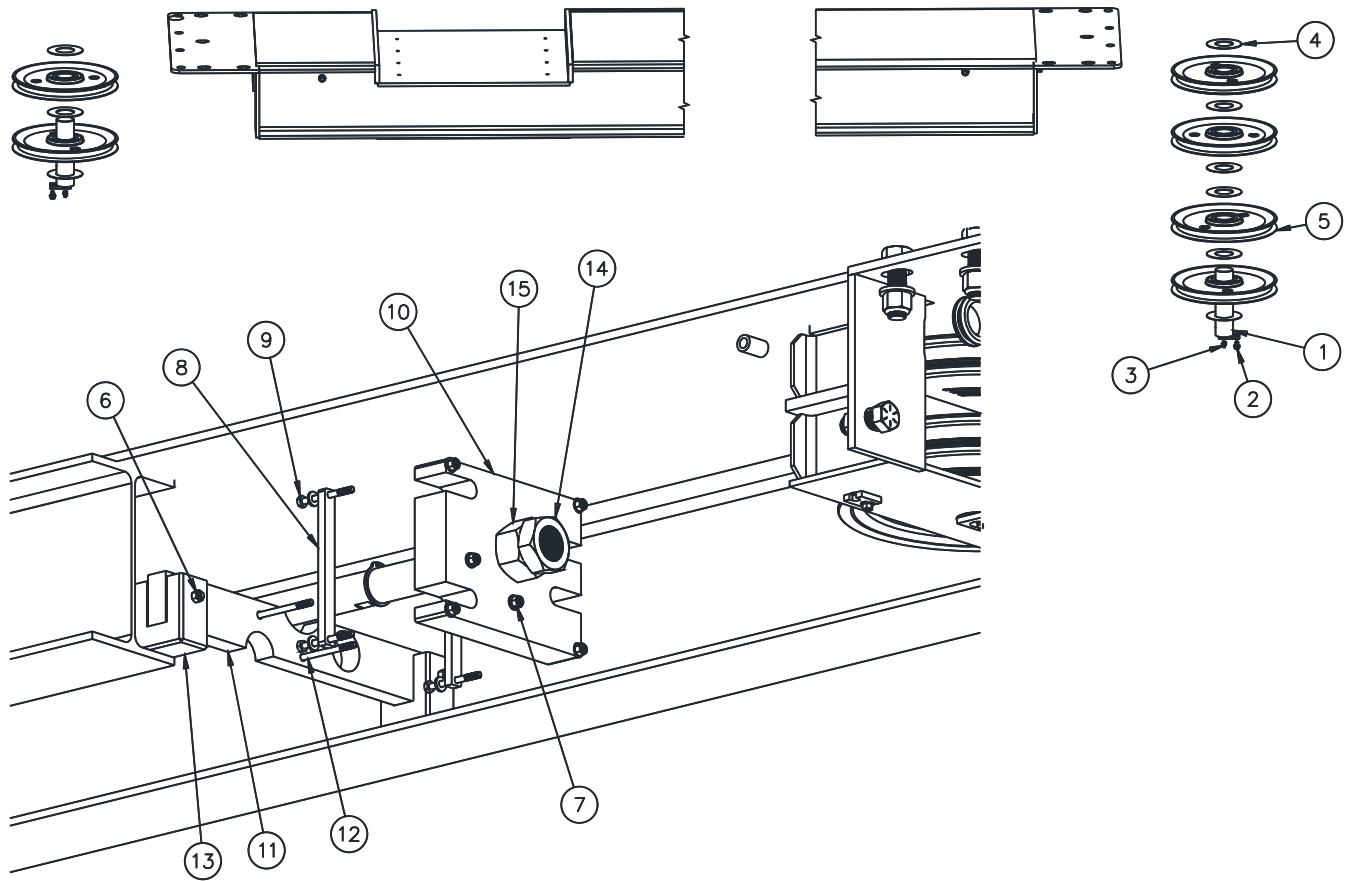

ITEM #	PART #	QTY/LIFT	DESCRIPTION
1	8430-0317	2	TRK SHEEVE PIN, WLD, WFP-30
2	92979a241	2	5/16"-18, 1/4" LENGTH FLANGE HEX CAP SCREW
3	1095k42	2	1/4"-28 TAPER ZERK GREASE FITTING
4	7430-0423	9	SPACER SHEAVE
5	9430-0331	6	1.25X 12 CABLE SHEAVE ASSEMBLY
6	91257A574	2	1/4"-28, 3.25" LENGTH CAP SCREW
7	97135A215	8	1/4"-28 NYLON LOCKNUT
8	7430-0324	2	HYDRAULIC END CONNECTOR CABLE RETAINER
9	91257A573	4	1/4"-28, 2.75" LENGTH CAP SCREW
10	7430-0424	1	CABLE CONNECTOR
	9430-0308	1	MAIN ALIG TRACK ASSY
11	7430-0459	1	ANTI-ROTATING BAR
12	91257A571	2	1/4"-28, 4.0" LENGTH CAP SCREW
13	7430-0460	2	ANTI ROTATING RUB BLOCK
14	93839A865	1	1 1/2"-12 ZC YW-CHRME PLT STEEL THIN HEX NUT, GR 8
15	94895A865	1	1-1/2"-12 ZC YW-CHRME PLT STEEL HEX NUT, GR 8

Replace all worn, damaged, or broken parts with parts approved by **Challenger Lifts Inc.** or with parts meeting **Challenger Lifts Inc.** specifications.

Contact your local Challenger Lifts Parts Distributor for pricing and availability.
(Call Challenger Lifts Inc. (502) 625-0700 for the Parts Distributor in your area)

PARTS BREAKDOWN (continued)

Fig D. Cross Beam

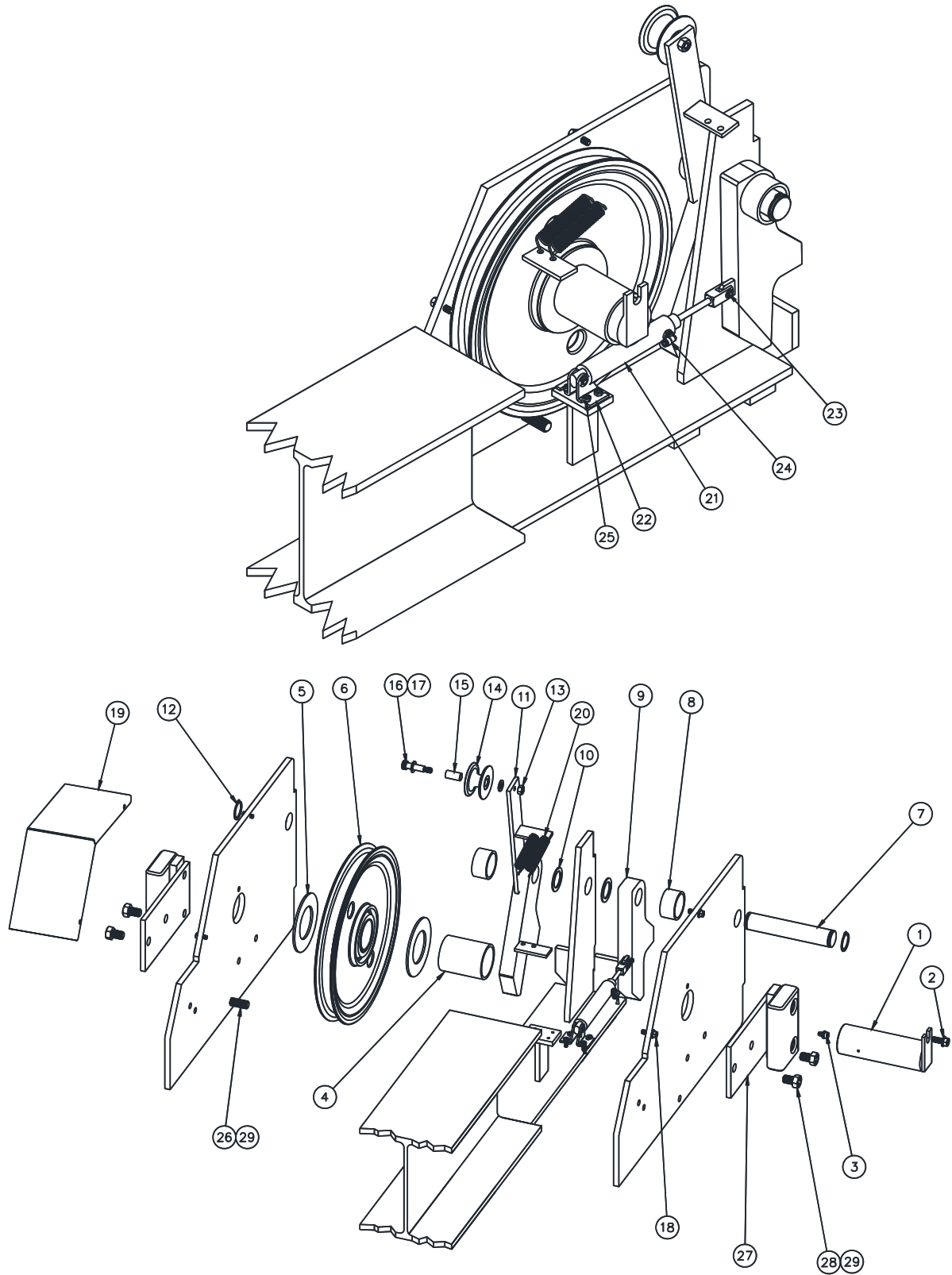

Model 4030
Installation, Operation and Maintenance

ITEM #	PART #	QTY/LIFT	DESCRIPTION
1	8430-0318	4	XR PIN WLD, WFP30
2	92979A249	4	5/16"-18", 3/4" FRLANGED HEX CAP SCREW
3	1095K42	4	1/4"-28 TAPER ZERK GREASE FITTING
4	7430-3009	4	SPACER SHEAVE SHAFT
5	7430-3004	8	SPACER SHEAVE, WFP30, CABLE
6	9430-0331	4	1.25 X 12 CABLE SHEAVE ASSEMBLY
7	7430-3011	4	LATCH MNT PIN, WFP30, CABLE
8	7430-0403	8	LATCH SPACER
9	8430-0304	4	PRIMARY SLACK LACK WLDMNT
10	97022A573	8	.06" ID, 2.125" OD, 1.5 THICK SHIM
11	8430-0302	2	SECONDARY SLACK LATCH WLDMNT LH
	8430-0303	2	SECONDARY SLACK LATCH WLDMNT RH
12	97633A320	4	1 1/8" SHAFT DIAMETER RETAINING RING
13	94895A030	4	5/16"-18 HEX NUT
14	7430-3007	4	SLK CAB ROLLER
	AA508-9	4	BEARING
16	91259A626	4	5/16"-18, 1.25" LENGTH SHOULDER SCREW
17	90126A031	8	3/8" SCREW SIZE ZC. PLT WASHER
18	92979A118	16	1/4"-20, 3/4" HEX CAP SCREW, GR-5
19	7430-3003	4	CROSS RAIL COVER
20	1004-0003	8	STEEL SPRING, 5.5" LTH, .562" OD
21	1012-0005	4	AIR CYLINDER
22	6498K72	4	PIVOT BRACKET
23	6498K42	8	ROD CLEVIS PIN
24	SPL-2501	4	.156ID X .125MNPTPUSH-ON 90 CONN
25	92620A412	16	10-24", 1/2" LENGTH, HEX HEAD SCW
26	92620A720	4	1/2"-13. 2.0" LENGTH
27	9430-3500	8	Slide Blocks
28	92620A709	16	1/2"-13, 3/4" LENGTH HEX SCREW, ZC, GR8
29	91102A033	72	1/2" LOCK WASHER

Replace all worn, damaged, or broken parts with parts approved by **Challenger Lifts Inc.** or with parts meeting **Challenger Lifts Inc.** specifications.

Contact your local Challenger Lifts Parts Distributor for pricing and availability.
(Call Challenger Lifts Inc. (502) 625-0700 for the Parts Distributor in your area)

Model 4030
Installation, Operation and Maintenance

PARTS BREAKDOWN (continued)

Fig E. Air Lock Release

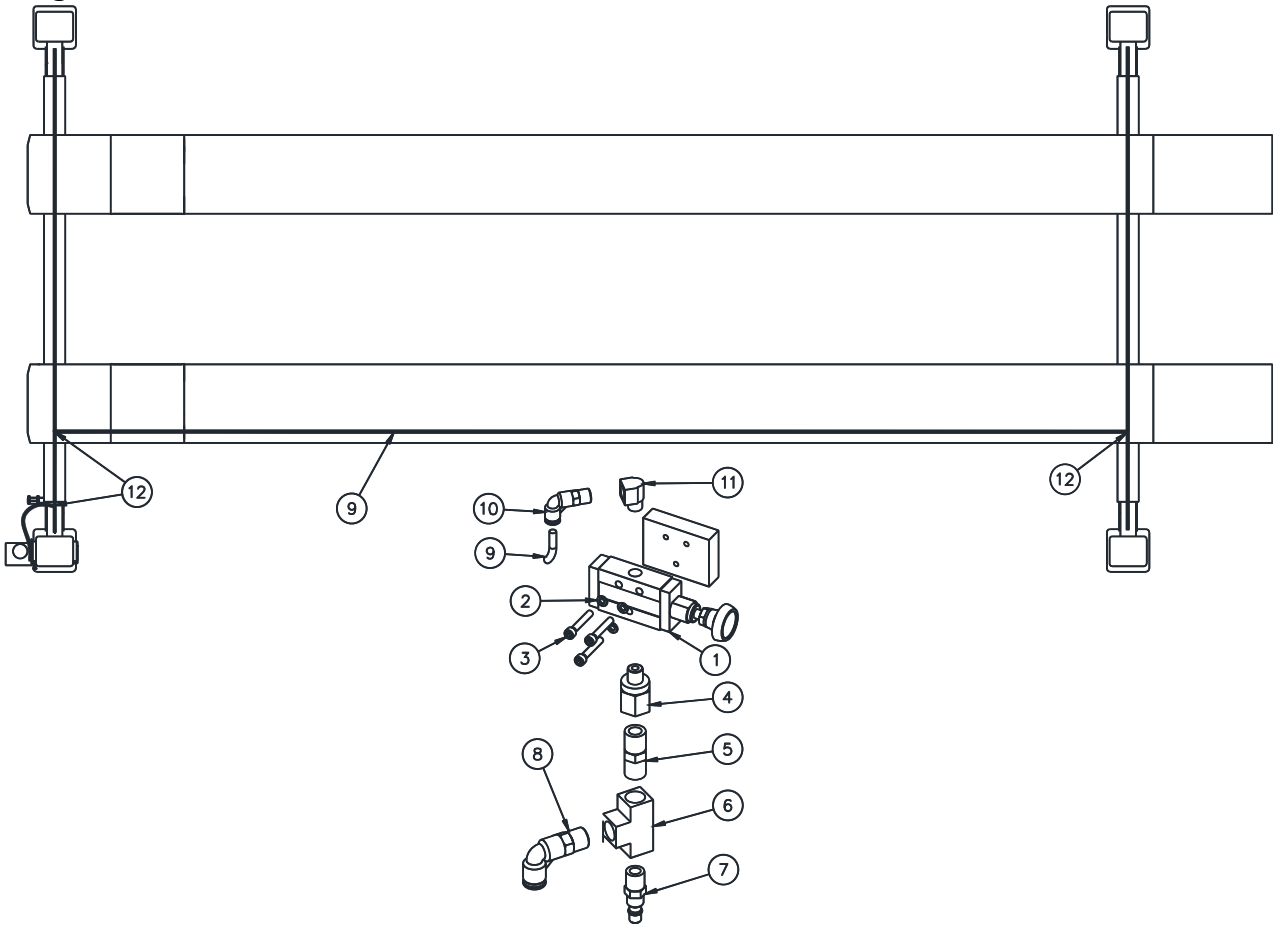

ITEM #	PART #	QTY/LIFT	DESCRIPTION
1	414411000	1	3-WAY PNEUMATIC VALVE
2	91102A002	3	#8 LOCK WASHER
3	91251A199	3	#8-32 SHCS X 1' LG
4	5402-02-04	1	1/8 MNPT X 1/4 FNPT STRAIGHT EXPANDER
5	5485K22	1	1/4 HEX NIPPLE
6	50785K72	1	1/4 FNPT TEE CONN.
7	6534K46	1	1/4 MNPT X MALE PNEUMATIC HOSE PLUG
8	SPL - 6002	1	1/4 MNPT X 3/8 90 DEGREE PUSH-ON FITTING
9	PT23003BK	63FT	5/32" DIA. PLASTIC AIR LINE
10	SPL - 2501	1	1/8 MNPT X 5/32 90 DEGREE PUSH-ON FITTING
11	50785K41	1	1/8 MNPT X 1/8 FNPT 90 DEGREE STREET ELBOW
12	SPE - 25	3	AIRLINE T

Replace all worn, damaged, or broken parts with parts approved by **Challenger Lifts Inc.** or with parts meeting **Challenger Lifts Inc.** specifications.
Contact your local Challenger Lifts Parts Distributor for pricing and availability.
(Call Challenger Lifts Inc. (502) 625-0700 for the Parts Distributor in your area)

NOTES

REVISIONS

2020/11/16 – UPDATED ANSI/ALI ALCTV AND ANSI/ALI ALOIM. UPDATED 9430-331 TO 9430-0331.
2021/01/05 – CHANGE PBD 7430-0444 TO 9430-0331 SHEAVE ASSEMBLY AND DARKENED IMAGES.
2021/03/26 – CORRECTED 93839A585 TO 93839A858 IN PBD.
2021/08/04 – ADDED 8430-0303 SLACK LATCH RH TO PBD.
2023/11/30 – UPDATED ANSI/ALI REFERENCE MATERIAL. UPDATED ANCHOR REFERENCE MATERIAL.
PG. 8.
2024/03/20 – ADDED ANSI STANDARDS REFERENCE STATEMENT SECTION. PG. 4.