





6K SCISSOR LIFT MR6

This 6,000 lbs. lift, with six locking positions, saves valuable shop space while lifting small passenger cars to light-duty trucks for brake and tire service. Reach more vehicle lift points with included 3" & 7" Extension Adapters. Additional features include a rotating arm design with rubber pads and a low drive-over clearance.



REQUIREMENTS

-  **12' MINIMUM**
-  **12' RECOMMENDED**
-  **28' RECOMMENDED**
-  **208-230V, 1PH, 20A**

SPECIFICATIONS

MODEL NUMBER	MR6
Lifting Capacity	6,000 lbs.
Rise Height (A)	53"
Overall Length (B)	94"
Overall Width (C)	40"
Min. Collapsed Table Height (D)	5½"
Pad Height (Min.)	8⅝"
Pad Height (Max.)	60"
Hydraulic Hose	144"
Safety Lock Positions	6
Standard Motor/Voltage	1HP, 115v, 60Hz, 1Ph
Rise Time	45s
Min. Required Bay Size	10' x 22'

SERVICE BAY LAYOUT

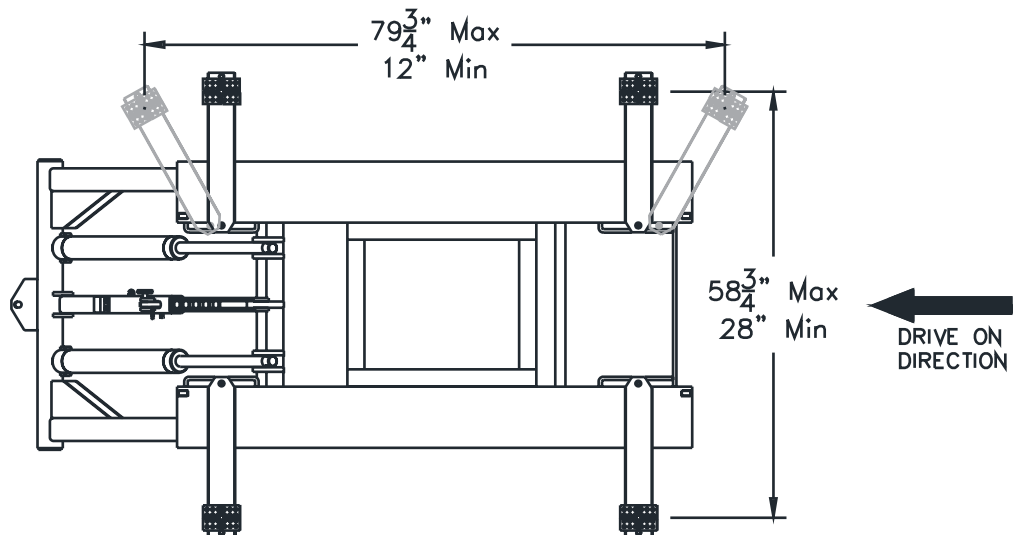

CONCRETE SPECS

4" thick, reinforced, free from cracks & seams, rated at 3500+ psi & cured minimum of 28 days