

CL Challenger Lifts

Installation, Operation & Maintenance Manual Multi-Purpose Short-Rise Lift

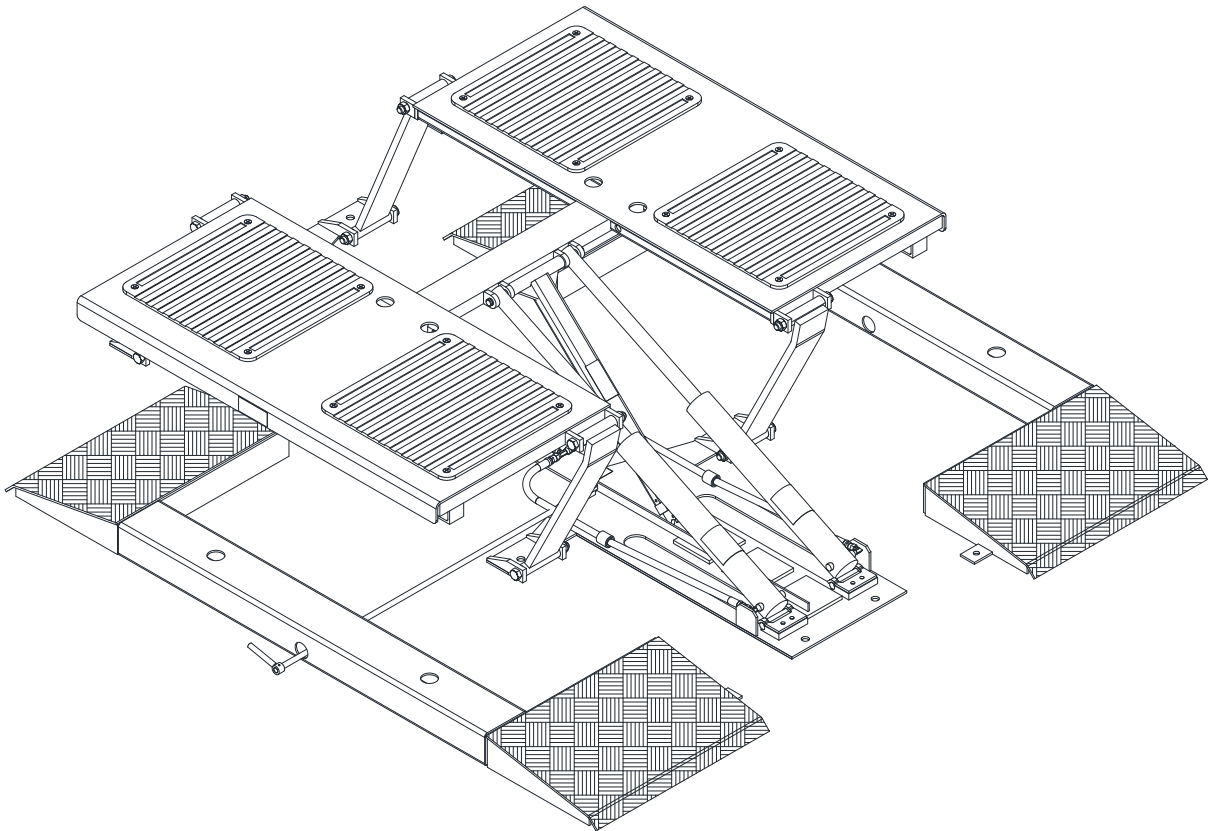

Model SRM10

10,000 LBS. CAPACITY

2311 South Park Rd Louisville, Kentucky 40219

Email: Challengerlifts@soe.freshdesk.com

Phone: 800-648-5438

IMPORTANT: READ THIS MANUAL COMPLETELY BEFORE
INSTALLING or OPERATING LIFT

General Specifications

See Figure 1A & 1B	SRM10	SRM10 (Flush Mount)
Rise Height	22"	17 3/4"
Lowered Height	4 1/4"	-
Lifting Capacity (Hydraulic Pressure @ Cap.)	10,000 lbs. (1720 PSI)	
Lock Heights	13 3/4", 18 1/4", 21 1/4"	9 1/2", 14 1/8", 17"
Overall Width	87 1/2"	73 1/4"
Overall Length	92 7/8"	85 1/2"
Rearward Movement	13 1/4"	
Motor	1HP, Single Phase, 60Hz, 115V (230V optional)	

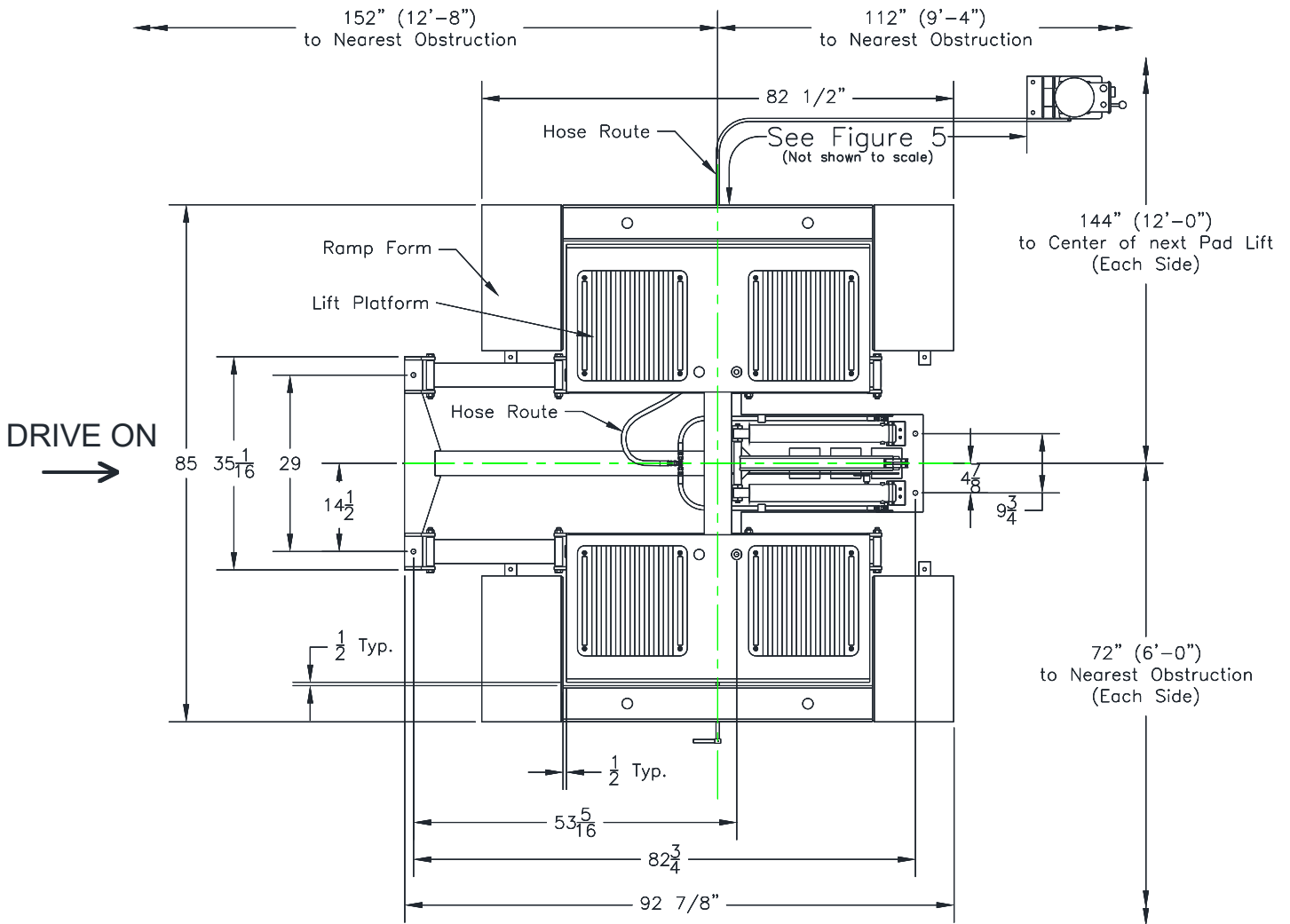

Fig. 1A General Surface Mount Layout

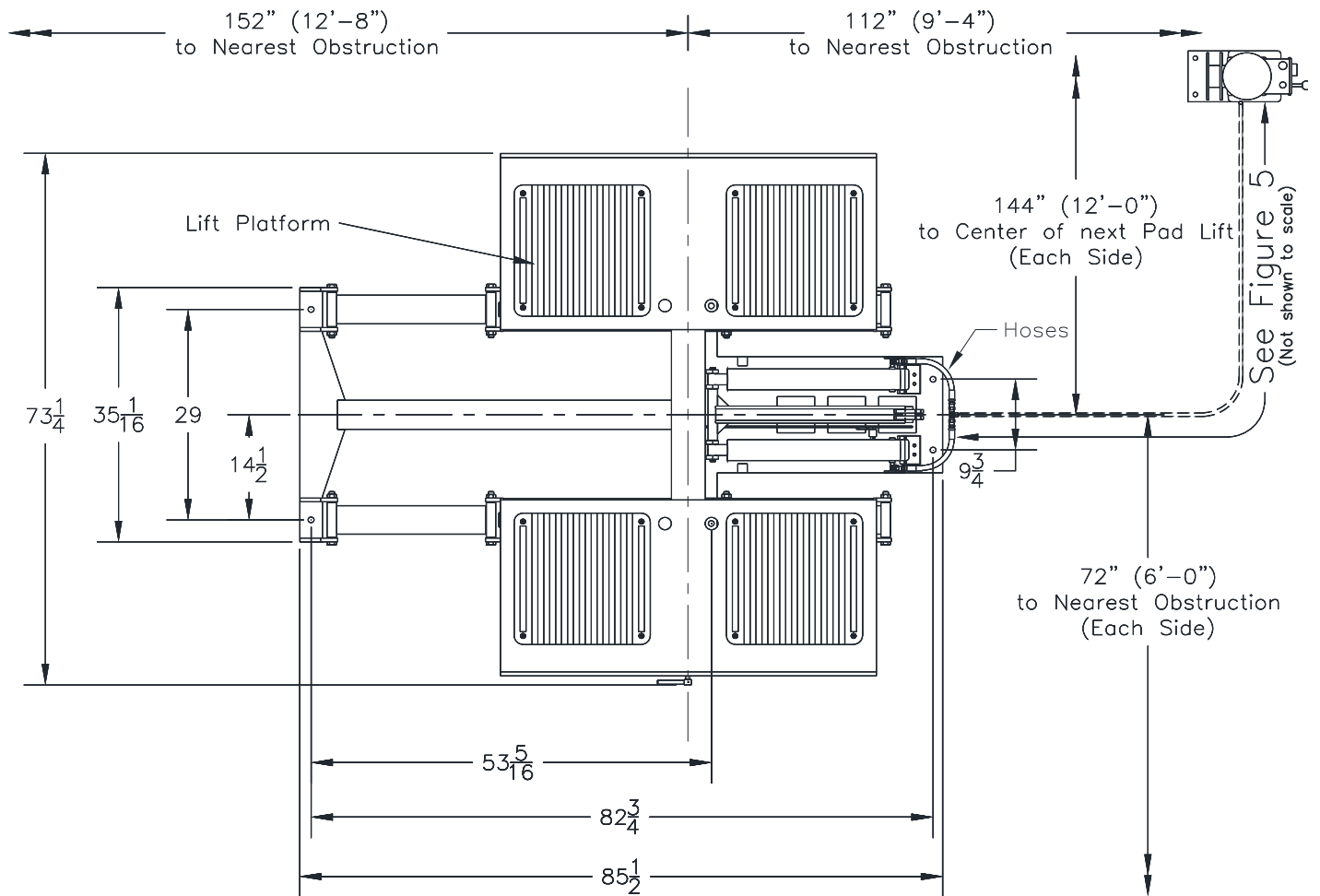
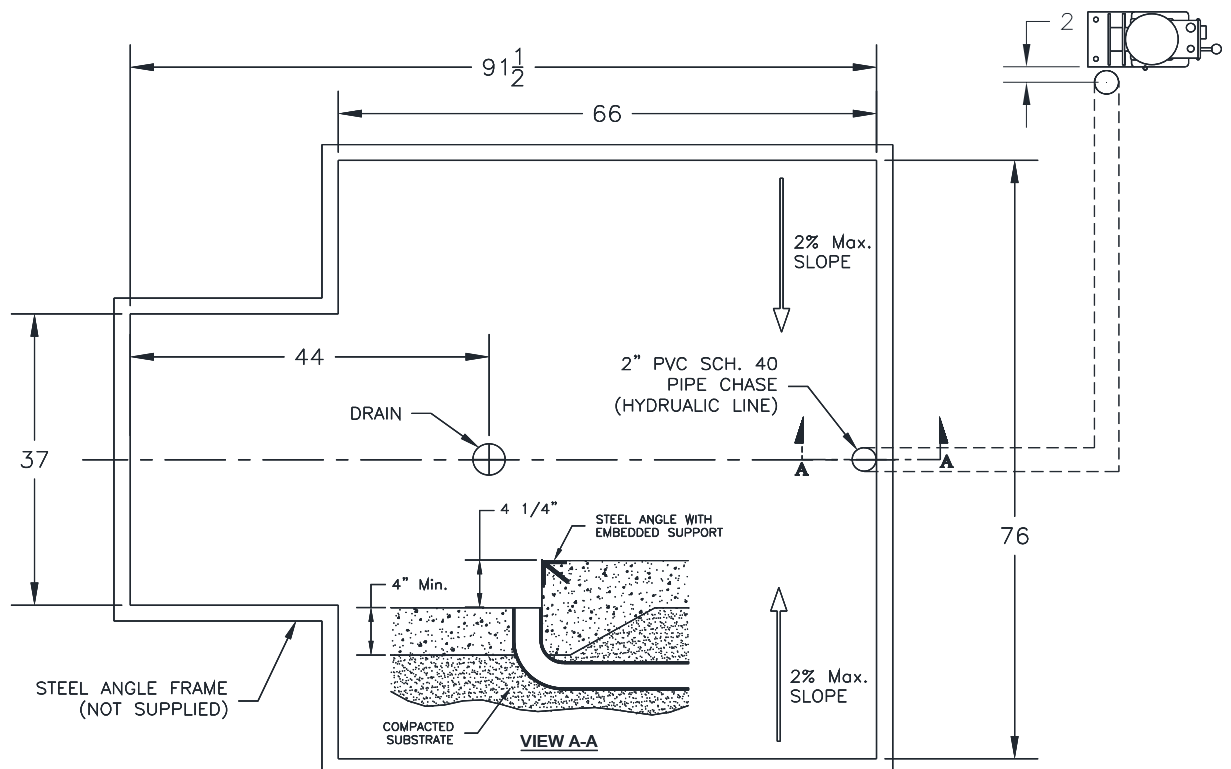

Fig. 1B - General Flush Mount Layout



**Fig. 2 - Flush Mount Pit Layout
(Provided By Others)**

BEFORE YOU BEGIN

Safety Notices and Decals

For your safety, and the safety of others, read and understand all of the safety notices and decals included here.

READ ENTIRE MANUAL BEFORE ASSEMBLING, INSTALLING, OPERATING, OR SERVICING THIS EQUIPMENT.

PROPER MAINTENANCE AND INSPECTION IS NECESSARY FOR SAFE OPERATION.

DO NOT operate a damaged lift.

Safety decals similar to those shown here are found on a properly installed lift. Be sure that all safety decals have been correctly installed on the lift. Verify that all authorized operators know the location of these decals and fully understand their meaning. Replace worn, faded, or damaged decals promptly.



WARNING Do not attempt to raise a vehicle on the lift until the lift has been correctly installed and adjusted as described in this manual.

LOCATION

This lift has been evaluated for indoor use only with an operating ambient temp. range of 5 – 40°C (41– 104°F). Outdoor Installation is Prohibited.

Edition of Referenced Materials

Where any ANSI standard or ALI materials are referenced within this manual, the most recent edition shall apply.

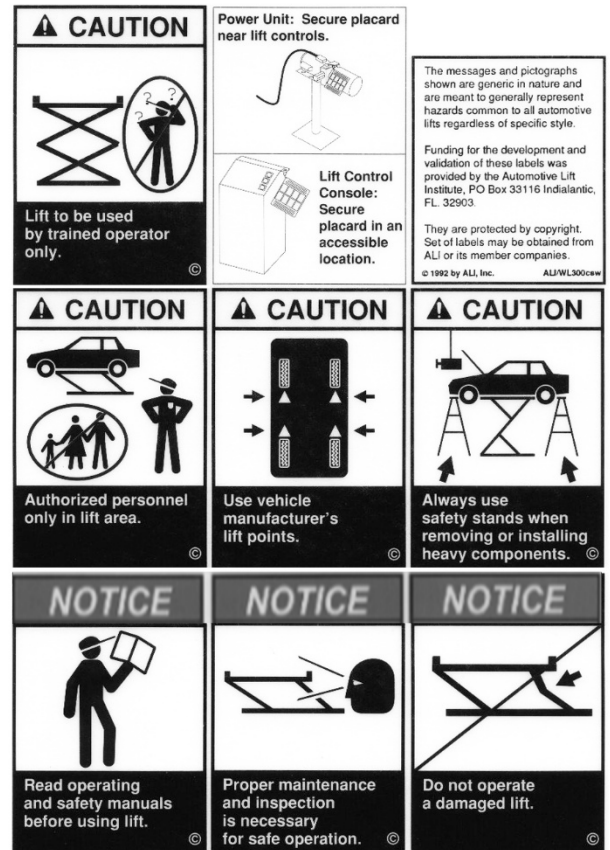

SAFETY WARNING LABELS FOR HINGED FRAME ENGAGING LIFTS

Lift Owner/User Responsibilities:

- A. This Safety Warning placard **SHALL** be displayed in a conspicuous location in the lift area.
- B. Use one of the mounting arrangements illustrated on back of this placard.
- C. These Safety Warning labels supplement other documents supplied with the lift.
- D. Be certain all lift operators read and understand these labels, operating instructions and other safety related information supplied with the lift.



RECEIVING

The shipment should be thoroughly inspected as soon as it is received. The signed bill of lading is acknowledgement by the carrier of receipt in good condition of shipment covered by our invoice. If any of the goods called for on this bill of lading are shorted or damaged, do not accept them until the carrier makes a notation on the freight bill of the shorted or damaged goods. Do this for your own protection.

NOTIFY **Challenger Lifts** AT ONCE if any hidden loss or damage is discovered after receipt

IT IS DIFFICULT TO COLLECT FOR LOSS OR DAMAGE AFTER YOU HAVE GIVEN THE CARRIER A CLEAR RECEIPT.

File your claim with **Challenger Lifts** promptly. Support your claim with copies of the bill of lading, freight bill, and photographs, if available.

Flooring

Be certain you have the proper concrete floor to properly handle the loaded lift. Floor should be in generally good condition with no large cracks, spalling or deterioration.

Minimum requirements for concrete are 4 inches minimum depth, with steel reinforcement, 3500 psi, cured for 28 days per local commercial practice. Floor should be level within 3/8 inch over the installation area. No anchors should be installed within 8 inches of any crack, edge, or expansion joint.

If these conditions cannot be met, pads can be poured to accommodate the lift. Pad must be a minimum of 8 ft x 8 ft x 1 ft minimum thickness, 3500 psi steel reinforced mechanically attached to existing floor.

Check with local building inspectors and/or permits office for any special instructions or approvals required for your installation.

A qualified person should be consulted to address seismic loads and other local or state requirements.



Failure by purchaser to provide the recommended mounting surface could result in unsatisfactory lift performance, property damage, or personal injury.

Vertical Clearance

Check the height of the area where the lift is to be installed. Clearance should be calculated based on the full raised height of the lift plus the height of the tallest vehicle you intend to service.



Failure by purchaser to provide adequate clearance could result in unsatisfactory lift performance, property damage, or personal injury.

Electrical Requirements

For lift installation and operation, it is necessary to have a dedicated 115V single-phase 60-cycle circuit with a 20-amp circuit breaker or time delay fuse.

Tools Required for Installation

1. Concrete hammer drill.
2. 3/4 inch & 1/2-inch solid drill bit with carbide tip to ANSI Standard B94.12-1977.
3. Wrenches: 7/16, 1/2, 9/16, 5/8, 11/16, 15/16, 1 1/8 inch
4. Ratchet drive with the following sockets: 7/16, 1/2, 9/16, 1 1/8 inch
5. Hammer
6. Funnel
7. Torque wrench: 50-to-250-foot pounds
8. Adjustable wrenches: 8 and 12 inch

General Anchor Bolt Instructions

1. The anchor bolts must be installed at least 8 inches from any crack, edge, or expansion joint.
2. Use a concrete hammer drill with a 3/4-inch carbide tip. Tip diameter to ANSI Standard B212.15 (.775 to .787).
3. Do not use excessively worn bits or bits which have been incorrectly sharpened.
4. Keep the drill in a perpendicular line while drilling.
5. Let the drill do the work. Do not apply excessive pressure.
6. Lift the drill up and down to remove dust and reduce binding.
7. Drill the hole through the floor or to a depth of 5 inches minimum. Drill completely through floor is possible.
8. Vacuum the dust from the hole. This increases the holding power of the anchor bolts.
9. Insert the assembled anchor bolt into the hole.
10. Tighten the bolt securely, and torque to 150 foot-pounds after installation is complete.

NOTE: Anchor bolt holes are designed for a tight fit. Using the lift frame, as a template will slightly enlarge the holes, allowing for proper tolerances once the anchor bolt is installed.

Installation

SAFETY REQUIREMENTS FOR INSTALLATION AND SERVICE

Refer to ANSI/ALI ALIS (current edition)

1. Locate the pad lift on a level concrete floor with adequate space on all sides. Minimum floor thickness is 4". Minimum floor strength is 3500 psi.



WARNING DO NOT install on asphalt or other similar unstable surface.

NOTE: The pad lift is to be installed with the cylinder end pointing towards the rear of bay. **Be aware of pad lift clearances.**

NOTE: At full rise, the lift will move the vehicle rearward 13 1/4" as shown in Fig. 3.

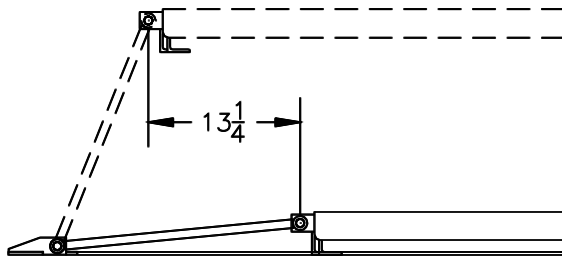

Fig. 3 Rearward Movement

Installation (Surface Mount)

2. Place lift and ramps in desired location. The ramp should be located to allow a minimum 1/2" clearance around the lift platform, See Fig.1A.

Installation (Flush Mount)

3. Before placing lift in pit, insert the lock release rod thru the pivot block welded to the base of the lift. Once lift is in pit, this rod will not be able to be installed due to its overall length.
4. Locate the pad lift in pit with adequate space on all sides.
5. Place front platforms in the pit with adequate space between the edge of the lift. Do not drill anchor holes until lift can be fully raised and lowered to ensure there are no interferences.

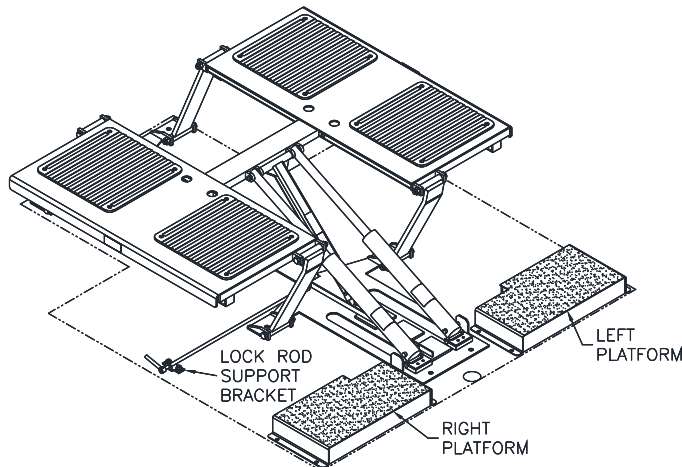

Fig. 4 Flush Mount Installation

Power Unit

CAUTION If lift is to be used in a paint booth, the electrical power unit **MUST** be mounted outside the booth.

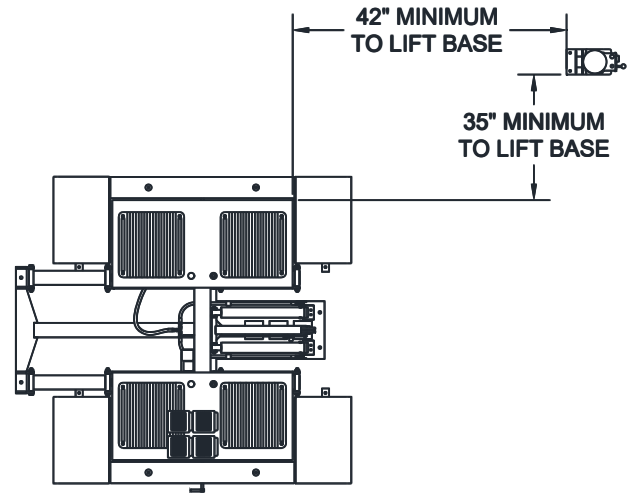

Fig. 5 Power Unit Location

6. Place Power Unit Stand as shown in Fig. 5 for surface mount or flush mount applications. Operator should be in a position to notice any misalignment of lifting pads or vehicle during operation. Challenger Lifts does not recommend placing the Power Unit in a different location or orientation and doing so would be the responsibility of the installer and/or end user.

IMPORTANT: Power Unit Controls should always be orientated so operator is facing the direction of the lift when operating the lift.

7. Anchor the power unit stand using concrete anchors provided. Mount the power unit to the stand with 5/16" hardware provided. (The power unit may also be mounted on a wall with the motor at a minimum of 18" above the floor. Purchase the appropriate mounting hardware to match the wall construction.)
8. Connect the end of the hydraulic hose with the 90-degree elbow to the pressure port on the power unit. Tighten securely to prevent leaking.

NOTE: To avoid damage to the hose, never run the hose under the lift or in the path of the automobile tires.

9. Fill the reservoir with 6 quarts clean 10wt anti-foam, anti-rust hydraulic oil or Dexron III ATF. **DO NOT USE OILS WITH DETERGENTS.**

10. Place the open end of the hose into a clean bucket.

11. Electrical connection:
 - a. **115V (standard wiring)** Plug power unit cord into a dedicated 115V single phase 60 cycle circuit with a 20-amp circuit breaker or time delay fuse.
 - b. **230V (non-standard wiring)** Connect Power Unit to suitable electrical source as shown in **Fig 7**.
12. For **Flush Mount only**, Route the Power Unit hose through the chase. Notice the tee connection is in front of the cylinders.
13. For **Surface Mount only**, Route the Power Unit hose along the expected path, into the holes in the Drive Side Ramp. Notice the tee connection is made in the center of the lift rearward of the cylinders.
14. Cycle the power unit (2 seconds on, 2 seconds off) until the hose expels a steady stream of fluid.
15. Connect the hose to the tee fitting on the lift.

Anchoring

16. There are (6) 13/16" diameter holes provided in the base frame for use with 3/4" anchor bolts. Once proper lift placement is complete, use a concrete hammer drill with a 3/4-inch carbide bit. Tip diameter should conform to ANSI Standard B212.15 (.775 to .787). Do not use excessively worn bits or bits which have been incorrectly sharpened. A core bit may be necessary if an obstruction is encountered. **Never substitute with a shorter anchor.** Insert anchor bolts into holes but do not tighten yet.

Shimming

17. The pad lift frame must not be twisted, bent or otherwise misaligned by uneven floors when anchoring. This will cause damage to the lift. Maximum out-of-level is 1/4" between all anchor points. If this is exceeded, it must be shimmed at that anchor point. If shimming exceeds 1/4" at any location, the surrounding area under the base must be grouted to eliminate improper loading of the base.
18. Once all shims are in place, tighten all 3/4" anchor bolts to 150 foot-pounds and all 1/2" anchor bolts to 50 foot-pounds.
19. Using the Power Unit raise the lift looking for leaks and understanding air will be bleeding from the system.

Lock Release

20. Assemble lock release mechanism using roll pins, hardware, and components provided as shown in the figure below.
21. For **Flush Mount only**, slide lock rod support bracket over free end of lock rod before the handle is attached to the end, See **Fig. 6**. Install the handle using the Spring Pin. *Also*

shown in Parts Breakdown at the end of this manual.

22. For **Surface Mount only**, make sure the Lock Release Rod Weld is routed through the Ramp. Install the Handle using the Spring Pin.

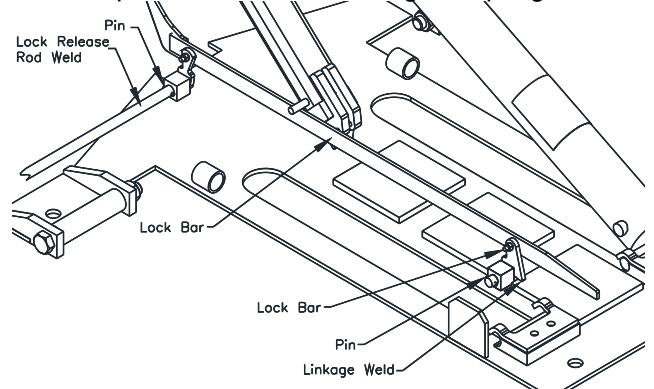

Fig. 6 Lock Release Bar
(Some parts removed for clarity)

23. Ensure lock release functions properly and remains disengaged during complete lowering of the lift once the lock handle is rotated to the upright position. When lift is close to fully lowered, the lock release should reset automatically, and the handle should be in a horizontal position.

Additional Anchoring

24. For **Surface Mount only**, there are (8) 5/8" diameter holes in the ramp forms for use with 1/2" anchor bolts. Use the holes in the ramp forms as a template and drill holes. Insert anchor bolts into holes but do not tighten yet.
25. For **Surface Mount only with Cover Acc**, use the nine 20" hose covers and one corner cover to protect the hose in a desired path using Fig. 5. Drill Ø1/4" holes using the hose covers as a template and secure the covers to the floor with the provided 1/4" drive anchors.
26. For **Flush Mount only**, ensure lock rod support bracket is shimmed as necessary for proper function of the lock release. Lock rod should pivot freely and be aligned with lock block near the center of the lift.
27. For **Flush Mount only**, there are (8) 5/8" diameter holes in the front platforms and (2) 5/8" holes in the lock rod support bracket. Use the platforms as a template and drill holes and insert anchor bolts. Locate lock rod support bracket near lock rod handle and align with pivot block near center of lift base. Ensure bracket does not interfere with bottom of lift structure when lowered before drilling holes. Drill holes and insert anchor bolts using bracket as a template. Do not tighten yet.

FINAL CHECKOUT PROCEDURE

28. Actuate the power unit to fully raise then fully lower the lift. Repeat 3 to 4 times.

CAUTION The power unit operates at high pressure.

29. Raise and lower lift a few times and check hose and fittings for leaks and tighten if required. Check for binding, misalignment or damage. Correct any unusual condition before raising vehicle.
30. Demonstrate the operation of the lift to the owner/operator/employer using a typical vehicle and review correct and safe lifting procedures using the **Lifting It Right** booklet as a guide.
31. Return all provided literature (including this manual) to the literature pack envelope and deliver the envelope to the owner/operator/employer.
32. Complete the online warranty registration (refer to the included warranty statement).

OPERATION PROCEDURE

SAFETY NOTICES AND DECALS

This product is furnished with graphic safety warning labels, which are reproduced on page 3 of these instructions. Do not remove or deface these warning labels or allow them to be removed or defaced. For your safety, and the safety of others, read and understand all of the safety notices and decals included.

OWNER/EMPLOYER RESPONSIBILITIES

This lift has been designed and constructed according to ANSI/ALI ALCTV standard. The standard applies to lift manufactures, as well as to owners and employers. The owner/employer's responsibilities as prescribed by ANSI/ALI ALOIM, are summarized below. For exact wording refer to the actual standard provided with this manual in the literature pack.

The Owner/Employer shall insure that the lift operators are qualified and that they are trained in the safe use and operation of the lift using the manufacturer's operating instructions; ALI/SM, *ALI Lifting It Right Safety Manual*; ALI/ST, *ALI Safety Tips Card*; ANSI/ALI ALOIM; *American National Standard for Automotive Lifts-Safety Requirements for Operation, Inspection and Maintenance*; ALI/WL Series, *ALI Uniform Warning Label Decals/Placards*; and in case of frame engaging lifts, ALI/LP-GUIDE, *Vehicle Lifting Points/Quick Reference Guide for Frame Engaging Lifts*.

The Owner/Employer shall establish procedures to periodically inspect the lift in accordance with the lift manufacturer's instructions or ANSI/ALOIM,

American National Standard for Automotive Lifts-Safety Requirements for Operation, Inspection and Maintenance; and the employer shall insure that the lift inspectors are qualified, and they are adequately trained in the inspection of the lift.

The Owner/Employer shall establish procedures to periodically maintain the lift in accordance with the lift manufacturer's instructions or ANSI/ALOIM, *American National Standard for Automotive Lifts-Safety Requirements for Operation, Inspection and Maintenance*; and the employer shall insure that the lift maintenance personnel are qualified, and they are adequately trained in the inspection of the lift.

The Owner/Employer shall maintain the periodic inspection and maintenance records recommended by the lift manufacturer or ANSI/ALOIM, *American National Standard for Automotive Lifts-Safety Requirements for Operation, Inspection and Maintenance*.

The Owner/Employer shall display the lift manufacturer's operating instructions; ALI/SM, *ALI Lifting It Right Safety Manual*; ALI/ST, *ALI Safety Tips Card*; ANSI/ALI ALOIM; *American National Standard for Automotive Lifts-Safety Requirements for Operation, Inspection and Maintenance*; and in case of frame engaging lift, ALI/LP-GUIDE, *Vehicle Lifting Points/Quick Reference Guide for Frame Engaging Lifts*; in a conspicuous location in the lift area convenient to the operator.

IMPORTANT SAFETY INSTRUCTIONS

When using your garage equipment, basic safety precautions should always be followed, including the following:

1. Read all instructions.
2. Care must be taken as burns can occur from touching hot parts.
3. To reduce the risk of fire, do not operate equipment in the vicinity of open containers of flammable liquids (gasoline).
4. Keep hair, loose clothing, fingers, and all parts of body away from moving parts.
5. Use only as described in this manual. Use only manufacturer's recommended attachments.
6. ALWAYS WEAR SAFETY GLASSES. Everyday eyeglasses only have impact resistant lenses; they are not safety glasses.

SAVE THESE INSTRUCTIONS

Operating Instructions

NOTE: After reviewing these instructions and all decals, get familiar with lift controls by running the lift through a few cycles before loading vehicle on lift.

Loading Vehicle

1. Be sure lift is fully lowered, and service bay is clear of all personnel before the vehicle is driven on to lift.
2. Position vehicle over lift having equal distance from front tire to end of front ramps and rear tire to end of rear ramps. Vehicle must also be centered side to side.

⚠ WARNING Lift is designed to raise the complete vehicle. **NEVER** use to raise just one end or side of vehicle.

NOTE: Some vehicles may have the manufacturer's recommended lift points identified by triangle shape marks located on its undercarriage. Also, there may be a label located on the right front door lock face showing specific vehicle lift points. If the vehicles' lift points are not identified, refer to the service garage lift points shown in **Fig. 7**. **ALWAYS** follow the operating instructions supplied with the lift.

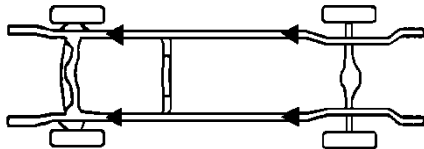

Ladder

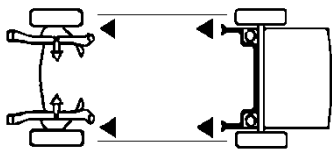

Unitized

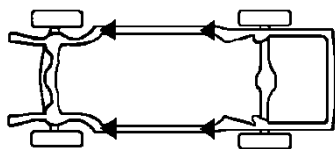

Perimeter

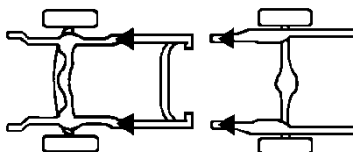

Stub

Fig. 7 Service Garage Lift Points

CAUTION Most specialty or modified vehicles cannot be raised on a frame engaging or pad lift. Contact vehicle manufacturer for raising or jacking details.

3. Before lifting the vehicle be sure that:
 - A. Individual axle weight of vehicle does not exceed one-half lift capacity. See safety instructions (capacity).
 - B. Spacer pads are in secure contact with frame at vehicle manufacturer's recommended lift points.
 - C. Vehicle is stable on lift and neither front nor rear heavy.
 - D. Use optional 4 3/4" and 6 3/4" spacer pads if additional height between lift and vehicle is required to clear underbody parts as shown in **Fig. 8**.

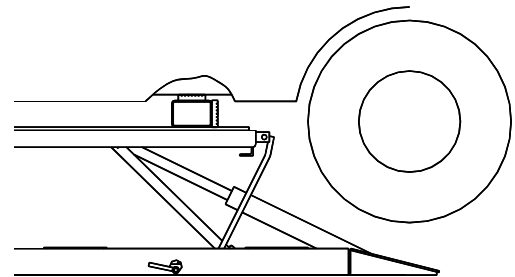

Fig. 8 Optional Spacer Pads

CAUTION Always use minimum number of spacer pads to clear obstruction. Spacer pads should never be stacked more than (2) pads high in any combination.



CAUTION With some vehicles, the removal (or installation) of heavy components may cause a critical shift in balance and result in vehicle instability. Refer to the vehicle manufacturer's service manual for recommended procedures when performing these services.

Raising Vehicle

4. To raise lift:
 - A. Actuate **RAISE** switch on electric power unit.
 - B. Raise vehicle until tires clear floor.
 - C. Stop and check spacer pads for secure contact at manufacturer's recommended lift points.
 - D. Continue to raise to desired height **ONLY** if vehicle is secure on lift.
 - E. Once you have reached the required height set into lock by depressing the lowering handle.

Lowering Vehicle

5. To lower lift:

Stand clear of lift and vehicle when lowering.
Observe pinch point warning decals.

- A. Remove all tools or other objects from lift area.
- B. Raise vehicle approximately 1".
- C. Disengage lock by rotating the lock release handle clockwise until it stops.
- D. Push **LOWERING** valve handle to lower lift.

CAUTION Lowering handle must be held down to continue to lower lift. DO NOT override self-closing lift controls.

6. Before moving vehicle, remove any spacer pads and be sure lift is at the fully lowered position.

Loss of Power

If for any reason the lift will not raise off the locks or the locks will not retract, consult factory authorized personnel.

DO NOT OVERRIDE ANY SAFETY FEATURE IN AN ATTEMPT TO LOWER THE LIFT.

NOTE: The lock bar will reset automatically when the lift is fully lowered. If during the lowering process the lock bar resets before it gets to the fully lowered position, continue lowering by repeating steps 5 or 6 from above.

ELECTRICAL

Wiring Diagram

* EACH LIFT SHOULD HAVE A DEDICATED CIRCUIT WITH A DOUBLE POLE BREAKER OR TIME DELAY FUSE SIZED ACCORDING TO THE FOLLOWING CHART.

* WIRING MUST COMPLY WITH ALL LOCAL ELECTRICAL CODES.

* ELECTRICAL CODE REQUIRES A SERVICE DISCONNECT FOR THIS DEVICE. WE SUGGEST THIS SERVICE DISCONNECT BE LOCATED NEAR THE POINT OF OPERATION.

	1 ϕ 110-120V	1 ϕ 208-240V
1.5Hp	16amp	8.5amp

FOR SINGLE PHASE 115V

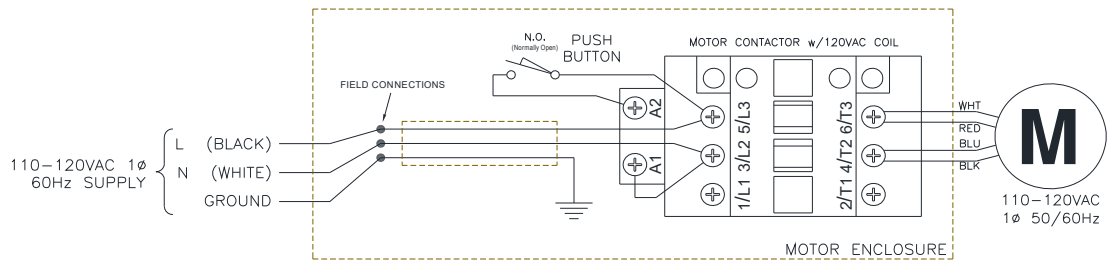

FOR SINGLE PHASE 230V

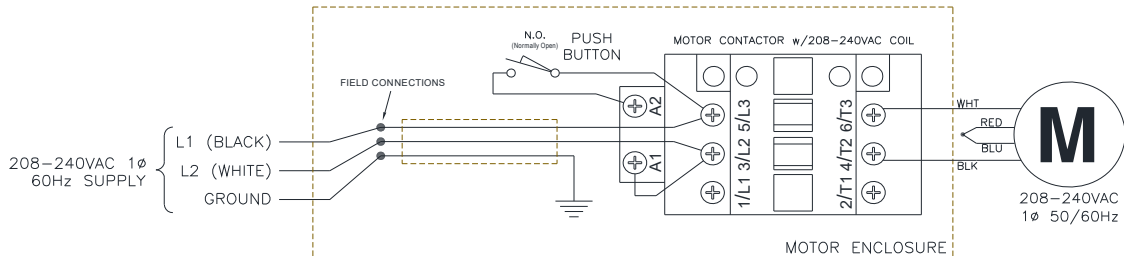

Fig. 9 Wiring Diagram

MAINTENANCE

To avoid personal injury, permit only qualified personnel to perform maintenance on this equipment. Maintenance personnel should follow lockout/tag out instructions per ANSI Z244.1.

The following maintenance points are suggested as the basis of a routine maintenance program. The actual maintenance program should be tailored to the installation. See ANSI/ALI ALOIM booklet for periodic inspection checklist and maintenance log sheet.

- If lift stops short of full rise or chatters, check fluid level and bleed both cylinders per Installation Instructions.
- Replace all Safety, Warning or Caution Labels if missing or damaged (**See *Installation instructions page 3.***)

See repair parts breakdown for replacement parts.

ALWAYS: Keep all anchor bolts tight. (1/2" Anchors 30 ft-lbs, 3/4" Anchors 80 ft-lbs).

ALWAYS: Keep all pivot bolts tight.

ALWAYS: Keep lift clean. Raise lift when cleaning floor area.

DAILY: Inspect spacer pads for damage or excessive wear.

DAILY: Check lock bar handle and release mechanism for damage or binding.

WEEKLY: Inspect all lift parts for signs of damage due to improper use.

MONTHLY: Lubricate lock bar pivot bolt and lock bar handle pivot points.

MONTHLY: Lubricate all hinge joints if there are signs of rusting.

MONTHLY: Visually inspect concrete floor for cracks and/or spalls within 12" of base plate

SEMI-ANNUALLY: Check fluid level of lift power unit and refill if required. Use only Dexron III ATF or 10wt anti-foam, anti-rust hydraulic oil. If fluid is required, inspect hose and connections and cylinder seals. Repair as required.

PARTS BREAKDOWN

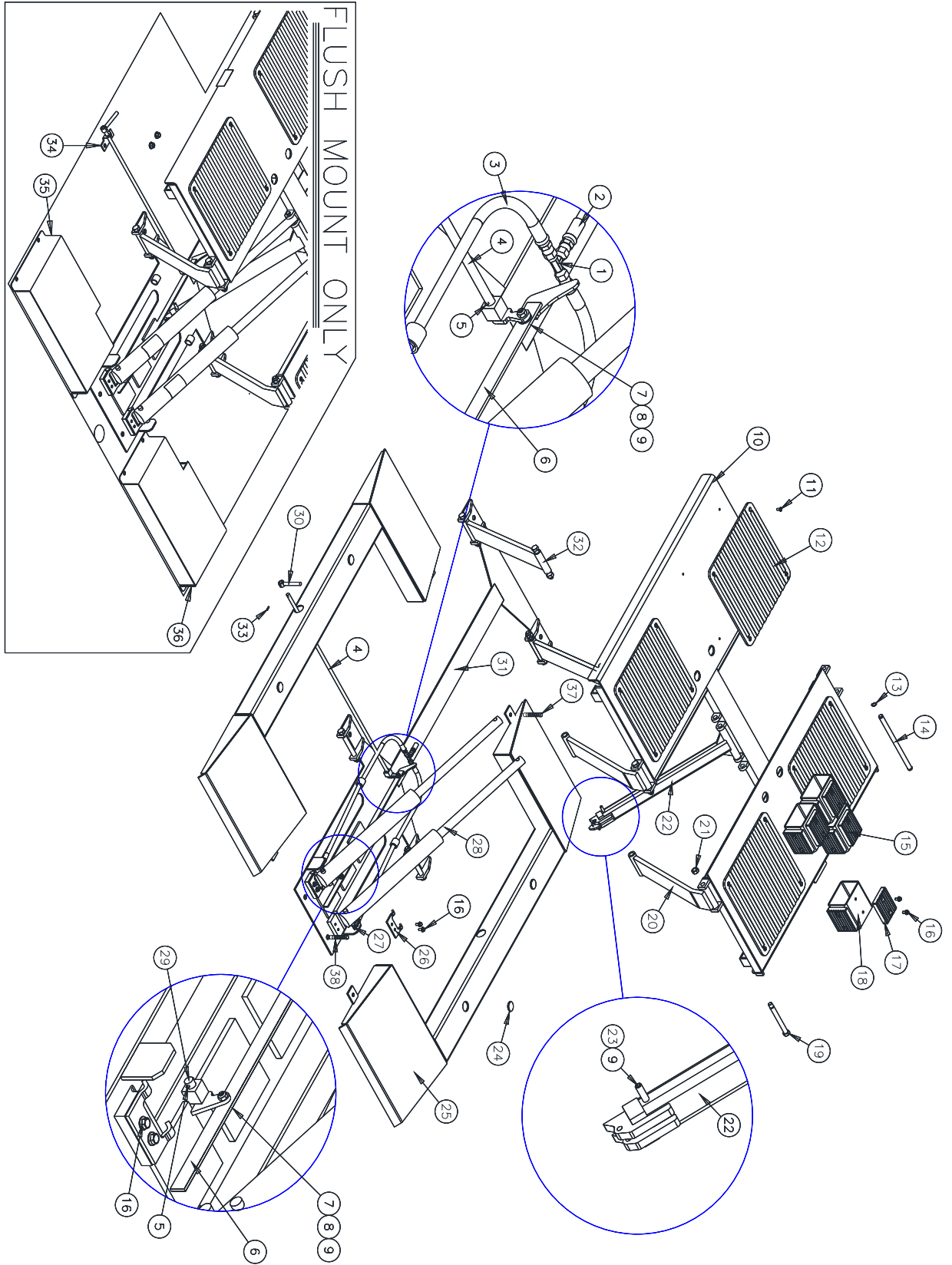

PARTS BREAKDOWN

ITEM #	PART #	QTY	DESCRIPTION
1	39103	1	#6 JIC Male Branch Tee
2	62-0011-22	1	22 Foot x 3/8" Hydraulic Hose, #6 JIC Female Ends
	62-0011-30		30 Foot x 3/8" Hydraulic Hose, #6 JIC Female Ends
3	62-0012	2	38" x 3/8" Hydraulic Hose, #6 JIC Female Ends (Surface Mount)
	SR-0132		16" x 3/8" Hydraulic Hose, #6 JIC Female Ends (Flush Mount)
4	SR-0100	1	Lock Release Rod Weld (Surface Mount)
	SR-0100S		Lock Release Rod Weld (Flush Mount)
5	SR-0122	2	5mm x 19mm Roll Pin
6	SR-0103	1	Lock Release Bar
7	SR-0103-3	2	8mm x 8mm Countersunk Shoulder Bolt
8	SR-0112	2	8mm Flat Washer
9	SR-0113	3	M6 Nylon Locknut
10	03-0383	1	Platform Weld
11	VS10-31-08	16	M8 x 13mm Phillips Flat Head Screw
12	TPJ3-01-06	4	Rubber Pad
13	SR-0121	2	19mm External Snap Ring
14	73-0934	1	Main Pivot Pin
15	01-0235	4	Spacer Block Assembly
16	B1153	20	M10 x 19mm Hex Flange Head Screw
17	482365	8	Rubber Lift Pad
18	74-0239	4	Spacer Tube
19	SR-0124	8	Leg Pivot Bolt, 19mm x 155mm with M18 Thread
20	03-0382	2	Front Leg Weld
21	SR-0114	8	M18 Nylon Locknut
22	03-0384	1	Lock Leg Weld
23	SR-0115	1	Lock Release Pin
24	SR-0120	4	Hole Plug, 46mm, White
25	03-0392	2	Ramp Weldment (Surface Mount)
26	73-0769	2	Cylinder Retainer
27	SR-0116	2	Union Elbow 1/4 NPT x #6 JIC Male
28	63-0022	2	Hydraulic Cylinder, 2 1/4 x 18
29	SR-0101	1	Linkage Weld
30	SR-0102	1	Lock Release Handle
31	03-0385	1	Base Weld
32	03-0381	2	Rear Leg Weld
33	SR-0126	1	5mm x 24mm Roll Pin
34	SR-0131	1	Lock Rod Support Bracket, Not Shown (Flush Mount)
35	SR-0130R	1	Front Platform, Right, Not Shown (Flush Mount)
36	SR-0130L	1	Front Platform, Left, Not Shown (Flush Mount)
37	68029	4	Anchor Bolt, 1/2 x 3 1/2" lg
38	31058	4	Anchor Bolt, 3/4" x 5 1/2" lg
	SR10-001	1	Height Adapter Kit (4 pieces item 17)
	SR10-002	1	Hose and Fitting Kit (includes items 1, 3, and 27)
	SR10-003	1	Hardware Box (Surface Mount)
	SRM10R-HW	1	Hardware Box (Flush Mount)
	SR10-004	1	Literature Pack

Replace all worn, damaged, or broken parts with parts approved by **Challenger Lifts Inc.**
or with parts meeting **Challenger Lifts Inc.** specifications.

Contact your local Challenger Lifts Parts Distributor for pricing and availability.
(Call **Challenger Lifts Inc.** (502) 625-0700 for the Parts Distributor in your area)

PARTS BREAKDOWN

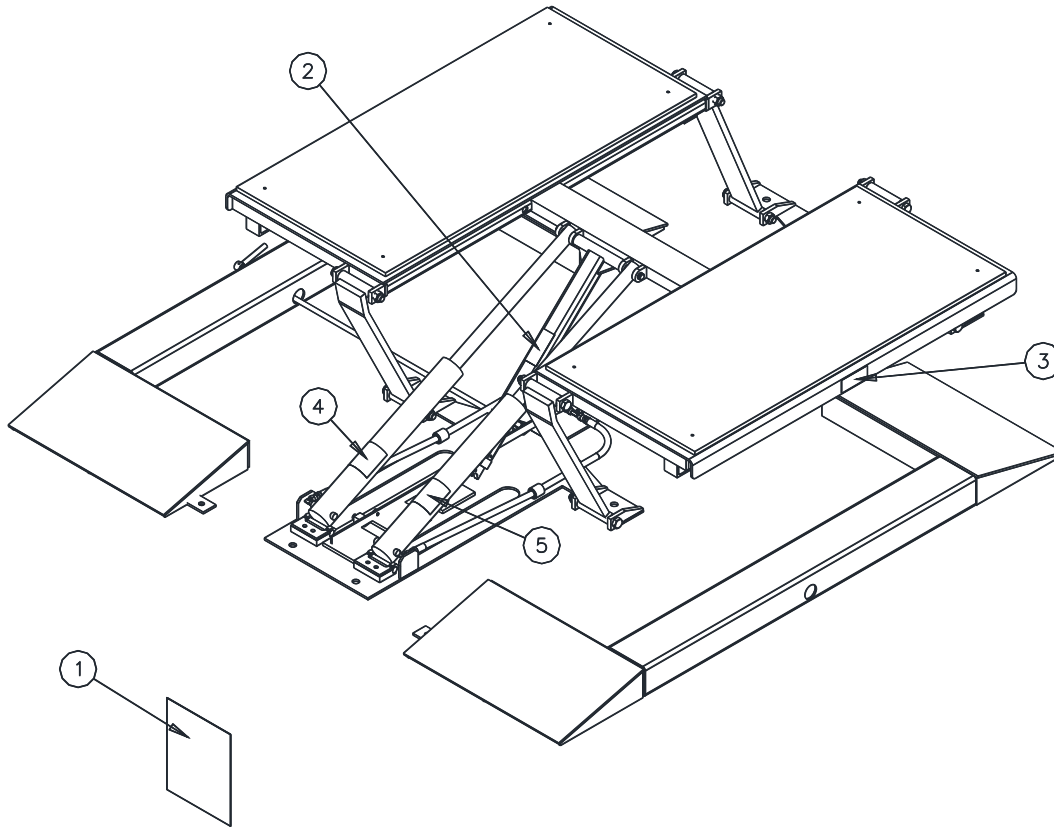

80-0147



80-0148



80-0150



80-0151

ITEM	QTY	PART NO.	DESCRIPTION
1	1	485412	ALI Warning Placard, Low Rise
2	1	80-0147	Caution Decal
3	2	80-0148	Warning Decal
4	1	80-0150	Caution Decal
5	1	80-0151	Warning Decal

Replace all worn, damaged, or broken parts with parts approved by **Challenger Lifts Inc.** or with parts meeting **Challenger Lifts Inc.** specifications.
 Contact your local Challenger Lifts Parts Distributor for pricing and availability.
 (Call **Challenger Lifts Inc.** (502) 625-0700 for the Parts Distributor in your area)

PARTS BREAKDOWN

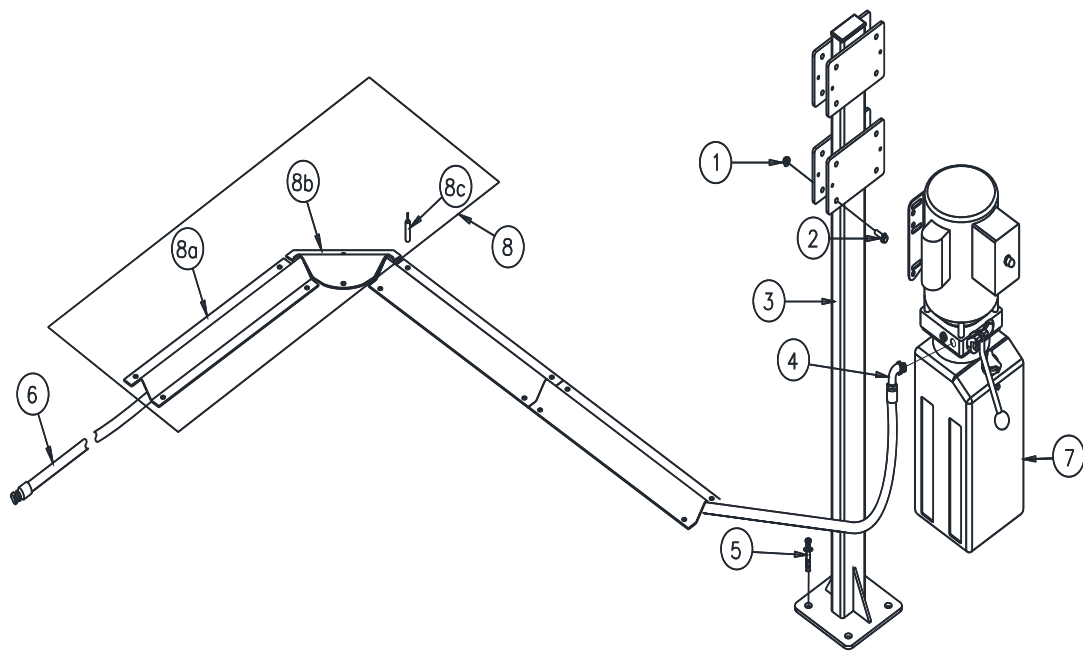

ITEM	QTY	PART NO.	DESCRIPTION
1	4	4100237	5/16-18 Hex Flange Nut
2	4	A1069	5/16-18 x 1 Hex Flange Head Bolt
3	1	10370-01/10370-00	Power Unit Stand / 7 Foot Stand
4	1	16167	9/16 O Ring x 37 Deg. Elbow
5	4	68029	Anchor Bolt, 1/2 x 3 1/2" lg
6	2	62-0011-22 or 62-0011-30	3/8" Hydraulic Hose x 22'lg or 30'lg
7	1	AB-1563-A-DLH	115VAC., Power Unit, 60Hz
		AB-1563-220	230VAC., Power Unit, 50/60Hz
8	1	10357	HOSE COVER KIT (OPTIONAL ACC.)
8a	9	10354-2	HOSE COVER (20")
8b	1	10354-3	HOSE COVER CORNER
8c	38	484985	1/4 x 1-1/2" DRIVE ANCHOR

Replace all worn, damaged, or broken parts with parts approved by **Challenger Lifts Inc.** or with parts meeting **Challenger Lifts Inc.** specifications.

Contact your local Challenger Lifts Parts Distributor for pricing and availability.
(Call **Challenger Lifts Inc.** (502) 625-0700 for the Parts Distributor in your area)

REVISIONS

- 2019/11/20 – ADDED ANCHOR BOLT IDENTIFICATION IN THE PARTS BREAKDOWN. UPDATED PARTS BREAKDOWN TEE FITTING FROM 60-0105 TO 39103.
- 2020/07/29 – CORRECTED SECOND LOCK HEIGHT FROM 18 3/8" TO 18 1/4". UPDATED THE POWER UNIT TO THE DELI PART NUMBER.
- 2020/01/08 – ADDED OPTIONAL HOSE COVER, FIXED IMAGES, ADDED FIG 5, UPDATED FIG 1A, ADDED STEP 6
- 2021/08/18 – UPDATED LOCATION TO INCLUDE OUTDOOR INSTALLATION IS PROHIBITED.
- 2025/01/02 – UPDATED ANSI/ALI REFERENCE MATERIAL. UPDATED NOTICE PLACARD.
- 2025/09/19 – PARTS BREAKDOWN TO INCLUDE NEW POWER UNIT STAND.
- 2026/04/30 – UPDATED WIRING DIAGRAM.