

CL Challenger Lifts

INSTALLATION, OPERATION & MAINTENANCE MANUAL

Two Post Surface Mounted Lift

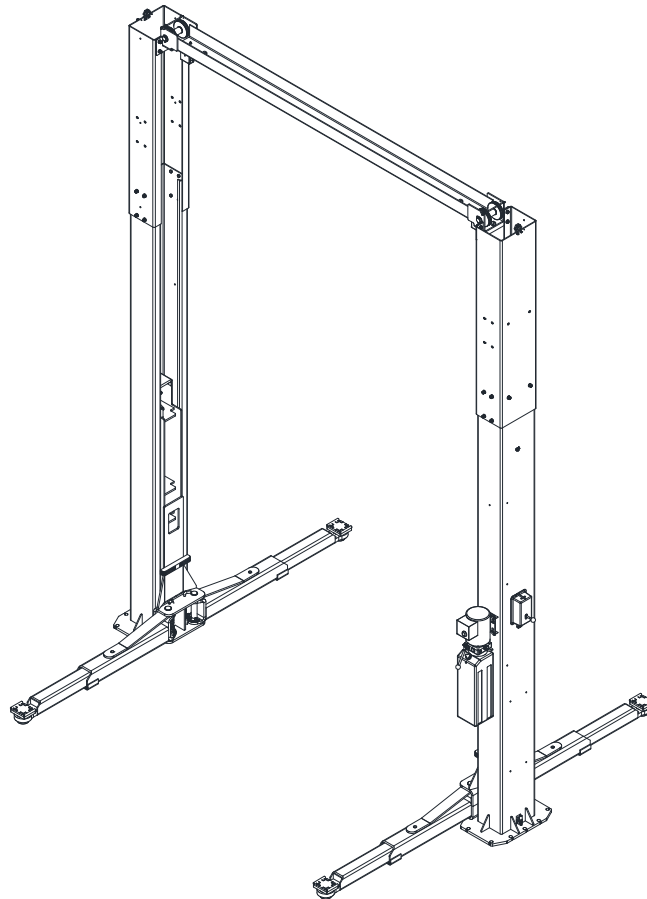

MODEL E15

**15,000 LBS. CAPACITY
3750 LBS. PER ARM**

2311 South Park Rd Louisville, Kentucky 40219

Email: Challengerlifts@soe.freshdesk.com

Phone: 800-648-5438

**IMPORTANT: READ THIS MANUAL COMPLETELY BEFORE
INSTALLING or OPERATING LIFT**

GENERAL SPECIFICATIONS

See Figure 1	E15	
A Rise Height (Screw Pads Highest Position)	77 3/4" (1975 mm)	
B Overall Height	14'-6" (4420mm) or 16'-6" (5030mm)	
C Overall Width	147 1/16" (3735 mm)	
D Drive-Thru Clearance	109 3/8" (2778 mm)	
E Floor to Overhead Switch	13'-10" (4216mm) or 15'-10" (4827mm)	
F Minimum Arm Reach	36 1/2" (927 mm)	
G Maximum Arm Reach	55" (1395 mm)	
H Screw Pad Height	5 1/4" / 6 3/4" (133mm/171mm)	
K Inside of Columns	122 1/4" (3105 mm)	
Arm Reach (Min.-Max.)	36.5"-55"	
Lifting Capacity *	15,000 lbs.	
Ceiling Height Required	175" (4445mm)	199" (5055mm)
Motor	2HP, Single Phase, 50/60Hz, 208-230 Optional – 2Hp, 3Ph, 50/60Hz, 208/230/460V	
Speed of Rise **	75 seconds	
Max Load Per Arm	3750 lbs. (1360 kg)	

* Lift capacity ratings are based on loads equally distributed on all four arms.

** Lifting and lowering speeds may vary depending on the weight of the vehicle.

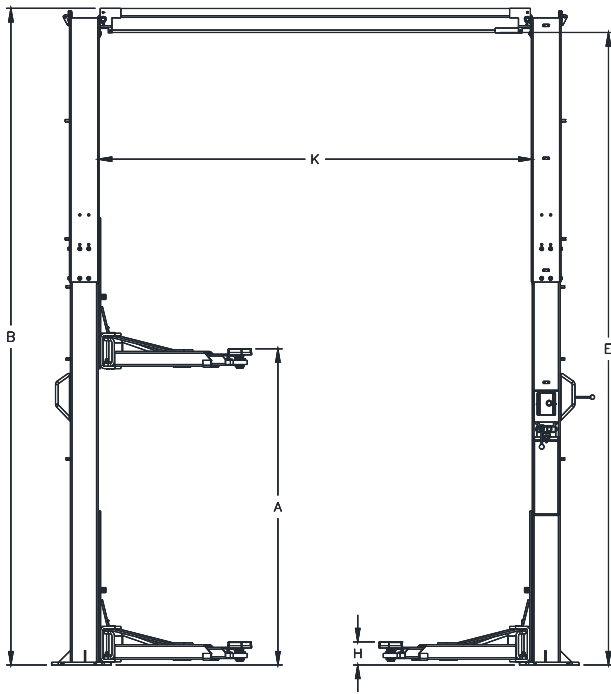

Fig 1a - General Specifications

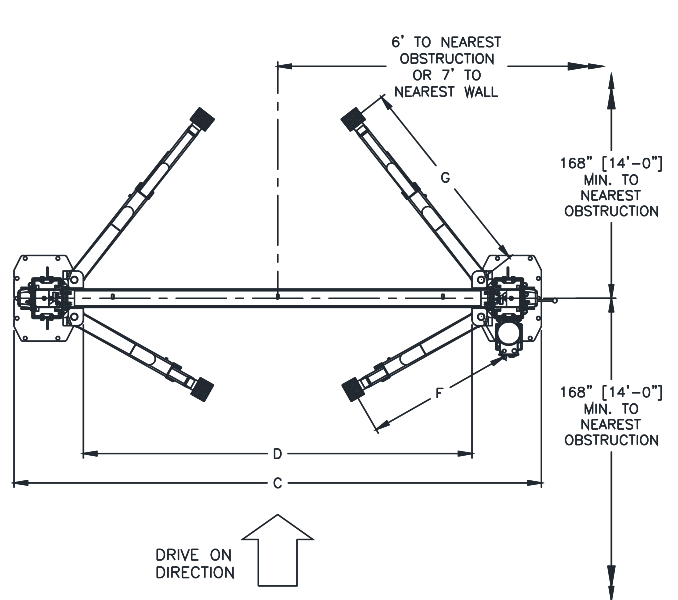

Fig 1b - Service Bay Layout

VERTICAL CLEARANCE

Check the height of the area where the lift is to be installed. Clearance should be calculated based on the full raised height of the lift.



WARNING Failure by purchaser to provide adequate clearance could result in unsatisfactory lift performance, property damage, or personal injury.

FLOORING

Be certain you have the proper concrete floor to properly handle the loaded lift. Floor should be in generally good condition with no large cracks, spalling or deterioration.

Minimum requirements for concrete are 4 inches minimum depth, with steel reinforcement, 3500 psi, cured for 28 days per local commercial practice. Floor should be level within 3/8 inch over the installation area. No anchors should be installed within 8 inches of any crack, edge, or expansion joint. If these conditions cannot be met, a pad may be poured to accommodate the lift.

Check with local building inspectors and/or permits office for any special instructions or approvals required for your installation.

A qualified person should be consulted to address seismic loads and other local or state requirements.



WARNING Failure by purchaser to provide the recommended mounting surface could result in unsatisfactory lift performance, property damage, or personal injury.

LOCATION

This lift has been evaluated for indoor use only with an operating ambient temp. range of 5 – 40°C (41– 104°F)

ELECTRICAL REQUIREMENTS

For lift installation and operation, it is necessary to have a dedicated circuit with circuit breaker or time delay fuse. Refer to wiring diagram for circuit sizing.

SAFETY NOTICES AND DECALS

For your safety, and the safety of others, read and understand all of the safety notices and decals included here.

READ ENTIRE MANUAL BEFORE ASSEMBLING, INSTALLING, OPERATING, OR SERVICING THIS EQUIPMENT.

PROPER MAINTENANCE AND INSPECTION IS NECESSARY FOR SAFE OPERATION.

DO NOT OPERATE A DAMAGED LIFT.

Safety decals similar to those shown here are found on a properly installed lift. Be sure that all safety decals have been correctly installed on the columns as described in this installation manual. Verify that all authorized operators know the location of these decals and fully understand their meaning. Replace worn, faded, or damaged decals promptly.



WARNING Do not attempt to raise a vehicle on the lift until the lift has been correctly installed and adjusted as described in this manual.

<p>NOTICE</p> <p>Read operating and safety manuals before using lift.</p>	<p>NOTICE</p> <p>Proper maintenance and inspection is necessary for safe operation.</p>	<p>If attachments, accessories, or configuration modifying components used on this lift are located in the load path and affect operation of the lift, affect the lift electrical listing, or affect intended vehicle accommodation; and if they are not certified for use on this lift, then the certification of this lift shall become null and void. Contact the participant for information pertaining to certified attachments, accessories, or configuration modifying components.</p> <p>NOTICE</p>
<p>NOTICE</p> <p>Do not operate a damaged lift.</p>	<p>The messages and pictographs shown are generic in nature and are meant to generally represent hazards common to all automotive lifts regardless of specific style.</p> <p>Replacement label sets may be obtained from the original lift manufacturer and ALI's member companies.</p> <p>Funding for the development and validation of these labels was provided by the Automotive Lift Institute, PO Box 85, Cortland, NY 13045. These labels are protected by copyright.</p> <p>www.autolift.org © 2006-2017 ALI/WLS101</p>	
<p>© 2011 by ALI, Inc. www.autolift.org ALI / WLSIA01</p>		

<p>CAUTION</p> <p>Lift to be used by trained operator only.</p>	<p>CAUTION</p> <p>Authorized personnel only in lift area.</p>	<p>WARNING</p> <p>Clear area if vehicle is in danger of falling.</p>	<p>WARNING</p> <p>Position vehicle with center of gravity midway between adapters.</p>
<p>CAUTION</p> <p>Use vehicle manufacturer's lift points.</p>	<p>CAUTION</p> <p>Always use safety stands when removing or installing heavy components.</p>	<p>WARNING</p> <p>Remain clear of lift when raising or lowering vehicle.</p>	<p>WARNING</p> <p>Avoid excessive rocking of vehicle while on lift.</p>
<p>CAUTION</p> <p>Use height extenders when necessary to ensure good contact.</p>	<p>CAUTION</p> <p>Auxiliary adapters may reduce load capacity.</p>	<p>WARNING</p> <p>Do not override self-closing lift controls.</p>	<p>WARNING</p> <p>Keep feet clear of lift while lowering.</p>
<p>The messages and pictographs shown are generic in nature and are meant to generally represent hazards common to all automotive lifts regardless of specific style.</p> <p>Funding for the development and validation of these labels was provided by the Automotive Lift Institute, PO Box 33116 Indianapolis, FL 32903.</p> <p>They are protected by copyright. Set of labels may be obtained from ALI or its member companies.</p> <p>© 1998 by ALI Inc. ALI/WLS101A</p>		<p>The messages and pictographs shown are generic in nature and are meant to generally represent hazards common to all automotive lifts regardless of specific style.</p> <p>Funding for the development and validation of these labels was provided by the Automotive Lift Institute, PO Box 33116 Indianapolis, FL 32903.</p> <p>They are protected by copyright. Set of labels may be obtained from ALI or its member companies.</p> <p>© 1998 by ALI Inc. ALI/WLS101A</p>	

RECEIVING

The shipment should be thoroughly inspected as soon as it is received. The signed bill of lading is acknowledgement by the carrier of receipt in good condition of shipment covered by our invoice.

If any of the goods called for on this bill of lading are shorted or damaged, do not accept them until the carrier makes a notation on the freight bill of the shorted or damaged goods. Do this for your own protection.

NOTIFY **Snap-On Equipment Customer Service** AT ONCE if any hidden loss or damage is discovered after receipt.

IT IS DIFFICULT TO COLLECT FOR LOSS OR DAMAGE AFTER YOU HAVE GIVEN THE CARRIER A CLEAR RECEIPT.

File your claim with **Snap-On Equipment** promptly. Support your claim with copies of the bill of lading, freight bill, and photographs, if available.

Component Packing List

PART #	QTY/ LIFT	DESCRIPTION
E15-00-1	1	Power Column Assembly
E15-00-2	1	Idler Column Assembly
E15-03-00	1	Overhead Assembly
E15-HW-A	1	Hardware Box
E15-01-02-01	2	Column Extension
E15-09-00	4	Arm Assemblies
E15-04-00	2	Synchronizer Cable Assembly
JSJ5-02-14	2	Lock Cover

Edition of Standards Referenced

Where any ANSI standard or ALI materials are referenced within this manual, the most recent edition shall apply.

INSTALLATION

SAFETY REQUIREMENTS FOR INSTALLATION AND SERVICE

Refer to ANSI/ALI ALIS (current edition)

IMPORTANT: Always wear safety glasses while installing lift.

TOOLS (MINIMUM REQUIRED)

- Tape measure, 16ft
- Chalk line
- 4ft level
- 10" adjustable wrench
- Metric open-end wrenches 10mm, 13mm, 14mm, 15mm, 17mm, 18mm, 19mm and 24mm
- Metric Allen Wrenches 4mm, 5mm, 6mm, and 8mm.
- Needle Nose pliers
- Snap Ring pliers.
- Hammer drill with 3/4" diameter carbide tipped bits.
- 2lb hammer
- Torque wrench: 150-foot pounds minimum with 1 1/8" socket
- 12 ft. Step ladder
- Anti-Seize lubricant (for arm pins and foot pad screw threads and stop rings)

LAYOUT

- Layout the service bay according to the architect's plans or owners' instructions (**see Fig 1b**). **Failure to install in this orientation can result in personal and property damage.** Be certain that the proper conditions exist, see page 3.
- Assemble column extension to column by lining up the correct set of holes and use the M12 x 30 Hex bolts. **Note: The column extensions are adjustable by 2'.** **Install Nut and Washer on exterior of the assembly.** Repeat for opposite column and extension.
- Using the Overall Width (C) Dimension from **Fig. 2**, chalk two parallel lines on the floor within 1/8" tolerance. Erect both column assemblies. Align the base plate edges to the chalk lines.

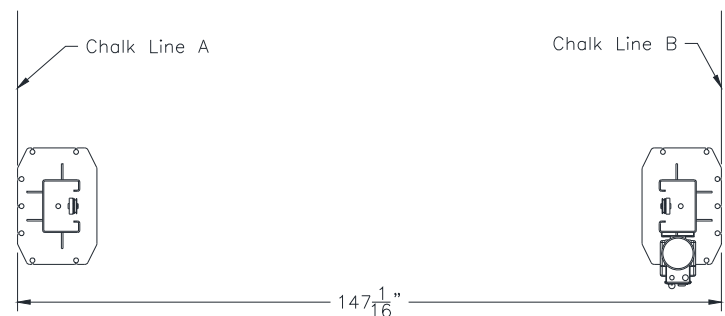

Fig. 2 – Column Layout

ANCHORING

Note:

- The anchor bolts must be installed at least 8" from any crack, edge, or expansion joint. Recheck the area around both base plates.
- Use a concrete hammer drill with a 3/4-inch carbide bit. Tip diameter should conform to ANSI Standard B212.15 (.775 to .787). Do not use excessively worn bits or bits which have been incorrectly sharpened. A core bit may be necessary if an obstruction is encountered.

Never substitute with shorter anchor.

- 4) Recheck "Inside of Columns" dimension (Fig. 1).
- 5) Using the base plate as a template, drill one anchor hole. Drill through the floor if possible or to a depth of 5 inches minimum.
- 6) Clean the hole inside and out.
- 7) Assemble a washer and nut to the anchor with nut just below impact section of bolt. Drive the anchor into the hole until the nut is 3/4" above the baseplate (leaving room for shims).

Complete steps 5 thru 7 for the seven (7) exposed anchors (one at a time) around each column.

- 8) Shim both columns to plumb using the shims provided as shown in Fig. 5. DO NOT shim more than 1/2" at any given point. Use a level no less than 24" in length to plumb columns.
- 9) Drive all the anchors until nut and washer contact baseplate.

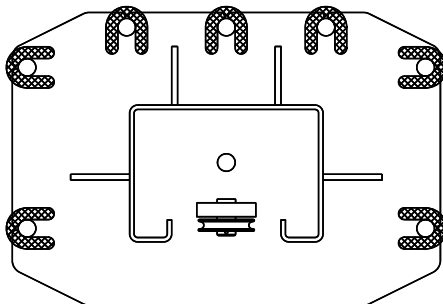

Fig. 3 – Column Shimming

- 10) Tighten power column anchors and recheck column for plumb. Re-shim if necessary. Torque to 150 foot-pounds to set anchors.

OVERHEAD/ LIMIT SWITCH

- 11) Raise and install Overhead Assembly using M12 x 30 Hex Bolts.

- 12) Install Overhead Limit Switch under the Overhead Assembly on the Power Side. Route cable around outside of column as shown in Fig. 4
- 13) Check idler column shimming. Use additional shims (see Fig. 4) to remove any gaps that may have been created while installing overhead beam. Tighten anchor bolts and recheck column for plumb. Torque to 150 foot-pounds.

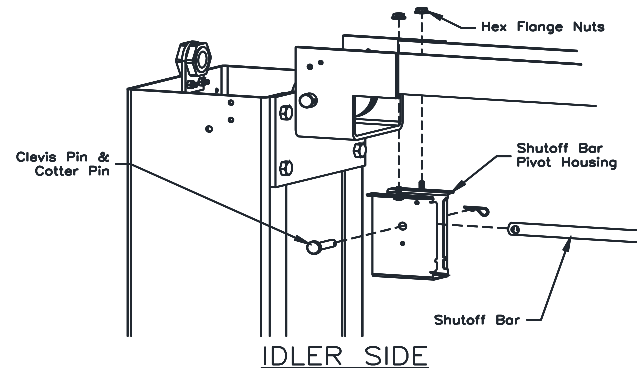
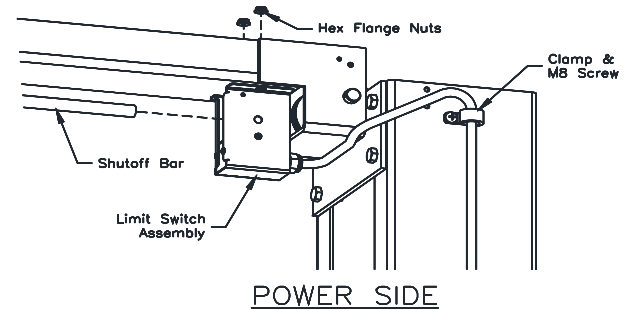

Fig. 4 - Limit Switch

SYNCHRONIZER CABLES

- 14) Manually raise each carriage into the second lock position.
- 15) **IMPORTANT:** Ensure that the lock pawl is engaged by attempting to manually disengage it. When properly engaged, the weight of the carriage will prevent it from moving.
- 16) At the upper beam sheave locations disassemble and reassemble the cable trapping rod to install the cable onto the sheave, See Fig. 5. To install the cable bottom sheave will need to be removed then reassembled.

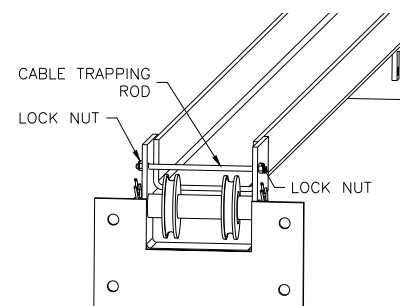

Fig. 5-Cable Trapping

- 17) Attach one end of synchronizing cable to carriage. See Fig. 6 for proper attachment.
- 18) Route cable up and over sheave in overhead. Follow across to other sheave on opposite column. Route down through carriage to sheave in bottom of column. Route under sheave and up to cable attachment.
- 19) Repeat for opposite side.

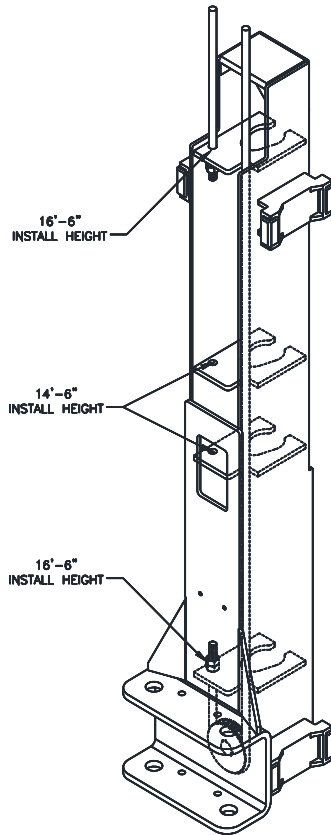

Fig. 6 – Synchronizing Cables

- 24) Beginning on the idler side, attach the idler extension hose to the cylinder elbow fitting (this hose is not needed for reduced height installations). Continue with the idler hose (long) up the backside of the column and through the plastic guide at the top of the column extension. Continue across the overhead through each of the guides as shown in Fig. 7 and down the backside of the power column.
- 25) Route the power hose from the power side cylinder elbow fitting up to the union tee provided. Connect idler hose and power unit hose to the union tee as shown in Fig. 7.

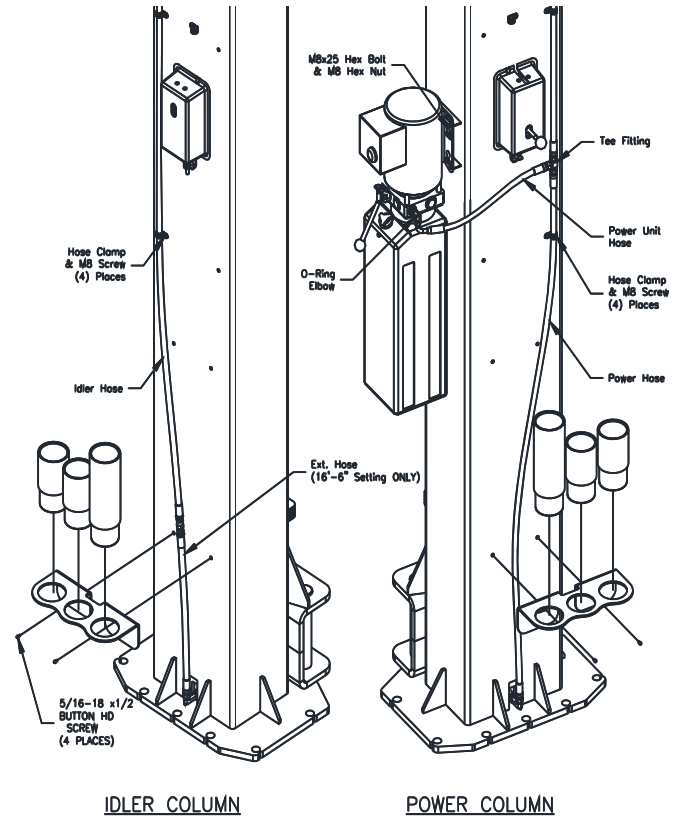

Fig. 7 – Hose Routing

POWER UNIT & HYDRAULIC LINES

- 20) Mount Power Unit to power column as shown in Fig. 7 using (4) M8 hex bolts and nuts.
- 21) Attach Hydraulic elbow fitting threading the O-Ring end into the power unit.
- 22) **IMPORTANT – To ensure proper hose fitting seal without damage to the fitting follow this procedure for each hose connection:** Screw flared fitting on finger tight. Rotate flared fitting 1 ½ flats or 90 degrees. Back the flared fitting off one full turn and repeat.
- 23) Thread power unit hose (short) to O-ring elbow on power unit.

- 26) **BE CERTAIN ALL FITTINGS AND CONNECTIONS ARE TIGHT. IT IS THE INSTALLERS RESPONSIBILITY TO ENSURE SYSTEM IS LEAK-FREE.** Fill the Power Unit with three gallons of clean 10wt anti-foam anti-rust hydraulic oil or Dexron III ATF. **DO NOT USE OILS WITH DETERGENTS.**
- 27) Hoses, cables, and limit switch cord should be routed as shown in Fig. 8 for power side column extension. Route lines for the idler side using the hose guide bracket and idler side pulley bracket.

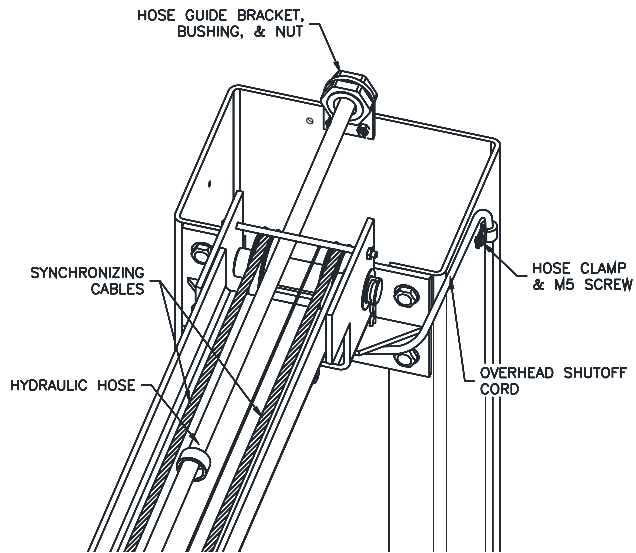

Fig. 8 – Power Side Routing

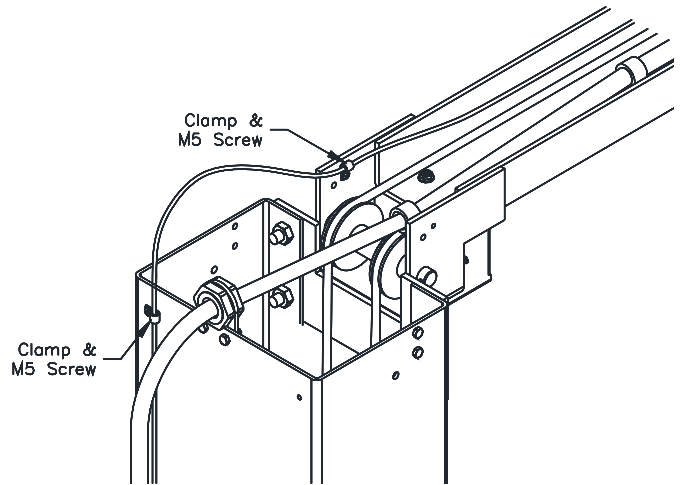

Fig. 10 – Lock Cable Routing

THE LOCK RELEASE CABLE ADJUSTMENT IS NOT COMPLETE UNTIL THE LIFT HAS BEEN LOWERED AND “FINAL ADJUSTMENTS” HAVE BEEN MADE.

LOCK RELEASE

- 28) Install Lock Release Rod, Clevis, and Knob to the Power Column Lock using one M10 Nut.
- 29) Attach Mechanical Lock Release Cable Assembly to each lock pawl. See **Fig. 9**.

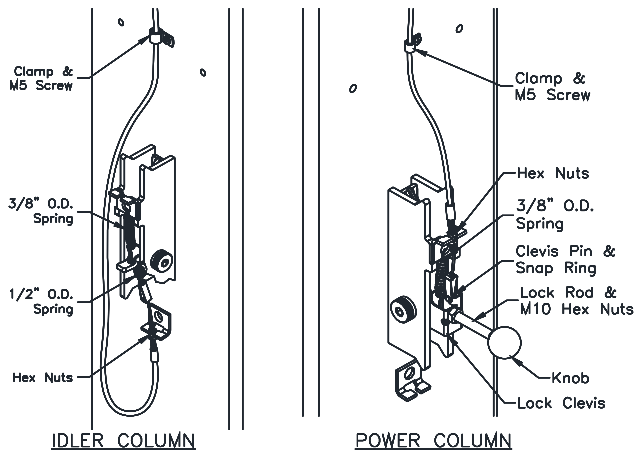

Fig. 9 – Lock Assembly

- 30) Secure Lock Release Cable at the top of each column extension as shown in **Fig. 10**. Lock Release Cable should be routed on the opposite side of the Overhead Beam as the Idler Hose to prevent interference.

ARM INSTALLATION

- 31) Lubricate the arm pin or carriage arm pin hole with “anti-seize” and install the arms as shown in **Fig. 11**. Once the set screw is finger tight against the arm pin, tighten ¼ turn with allen wrench.

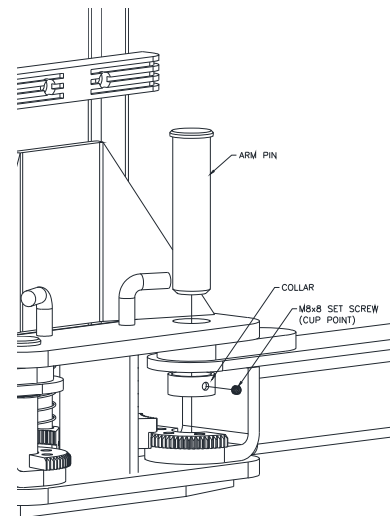

Fig. 11 –Arm Install

- 32) Ensure that the arm restraint gears engage and disengage properly. Arm restraints should disengage when lift is fully lowered. If any binding occurs, ensure that the large gear mounted to the arm has been factory installed tight against the arm pin.

- 33) Ensure arm stop hardware is present and adequately tightened so that spring lock washer is fully compressed for each arm. Check arm stop engagement by fully extending each arm. Properly installed arm stop hardware will prevent arm from becoming over-extended and possibly disassembled.



Loose or missing arm stop hardware may result in personal injury and/or property damage.

- 34) Extend the footpad to both extents and apply anti-seize to the three retaining rings and where the double screw makes contact with the base of the footpad.

ELECTRICAL

- 35) Refer to **Fig. 13 Wiring Diagram** for all steps under this heading.

Single Phase

- 36) Connect the Overhead Limit Switch Cord to Power Unit as shown.
37) Connect Power Unit to suitable electrical source as shown.

Three Phase

- 38) Power unit is factory wired for 240 volts. Refer to wiring diagram or motor plate for optional voltages.
39) Connect Contactor Enclosure to column. Mounting hardware should be centered on the column side to side to avoid the path of the slide blocks.
40) Connect Overhead Limit Switch Cord to Contactor as shown.
41) Connect Contactor to Power unit as shown. Connect Contactor to suitable electrical source as shown.

IMPORTANT: AFTER WIRING HAS BEEN COMPLETED, TEST OPERATION OF POWER UNIT & OVERHEAD LIMIT SWITCH. WHILE RAISING LIFT, OPERATE OVERHEAD SHUTOFF BAR. POWER UNIT MOTOR SHOULD STOP WHEN SHUTOFF BAR IS RAISED.

COLUMN DECAL PLACEMENT

- 42) Clean the surface of the columns before placing the decals.
43) Apply the Safety Decals (Pg. 3) 48" above the base plate on the power column and the Logo Decal 48" above the base plate on the idler column. **Fig. 12.**

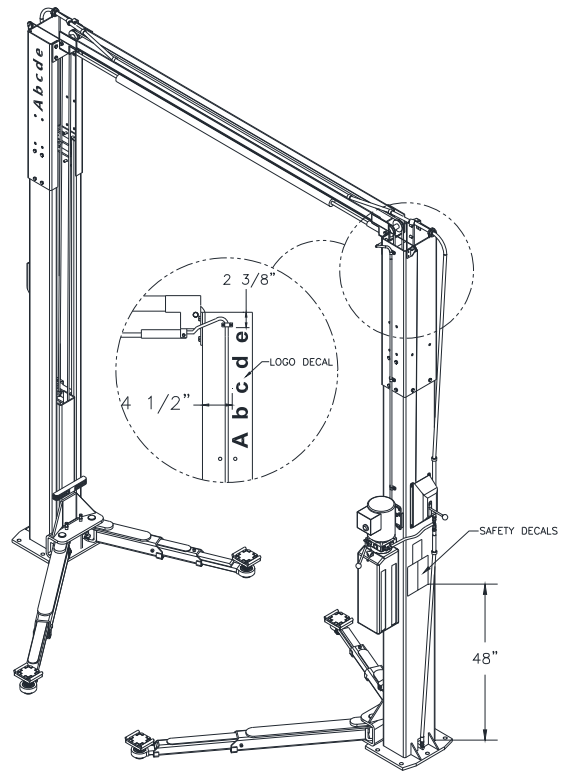

Fig. 12 – Safety & Logo Decal Placement

FINAL ADJUSTMENTS

HYDRAULICS

- 44) Lower the lift to the floor and raise the lift approximately one foot.
- 45) Start with Idler side first. Slowly and carefully loosen the bleed plug on top side of the cylinder just enough to allow the entrapped air to escape. Repeat for power side.
- 46) Raise lift 6 inches. Repeat step 45 until no air comes out of cylinder.
- 47) Pressure test hydraulic system. Energize power unit, raise lift to full rise and continue to run motor for additional 10 seconds. (NOTE: pressure relief will make a high pitch squeal sound for these 10 seconds.) Check hydraulic system for leaks.
- 48) Energize power unit again for 10 seconds. With a clean rag, wipe down both cylinder rods. (The cylinders are shipped with a small amount of clear anti-corrosive lubricant that will be forced out through the wiper when the lift reaches full rise.) **If lubricant is not wiped clean from the cylinder rod, the cylinder will appear to be leaking.**

SYNCHRONIZING CABLES

- 49) Raise lift and ensure carriages lower into same lock position.
- 50) Adjust synchronizing cables so the tension is equal in both cables and carriages are firmly sitting on locks.
- 51) Cycle lift to ensure that latches operate simultaneously.

LOCK RELEASE CABLE

- 52) Raise lift to a lock position but don't set into the lock. Pull and release Power Column lock release handle while watching Idler Column lock. Adjust Cable tension by removing slack and retightening cable clamp at the power side. **IMPORTANT: IF IDLER SIDE LOCK PAWL DOES NOT FULLY DISENGAGE, DAMAGE MAY RESULT TO IDLER SIDE CARRIAGE AND OR CABLE SYNCHRONIZING SYSTEM.**
- 53) Tighten and trim wire ties.
- 54) Remove lock release knob and install both covers. Replace lock release knob.

OWNER/OPERATOR CHECKLIST

- 55) Demonstrate the operation of the lift to the owner/operator and review correct and safe lifting procedures using the Lifting It Right booklet as a guide.

Wiring Diagram

* EACH LIFT SHOULD HAVE A DEDICATED CIRCUIT WITH A DOUBLE POLE (THREE POLE FOR 3 PHASE) BREAKER OR TIME DELAY FUSE SIZED ACCORDING TO THE FOLLOWING CHART.

	1 ϕ 208-240V	3 ϕ 208V	3 ϕ 220-240V	3 ϕ 440-480V
2Hp	30amp	15amp	15amp	5amp

* WIRING MUST COMPLY WITH ALL LOCAL ELECTRICAL CODES.

* ELECTRICAL CODE REQUIRES A SERVICE DISCONNECT FOR THIS DEVICE. WE SUGGEST THIS SERVICE DISCONNECT BE LOCATED NEAR THE POINT OF OPERATION.

FOR SINGLE PHASE

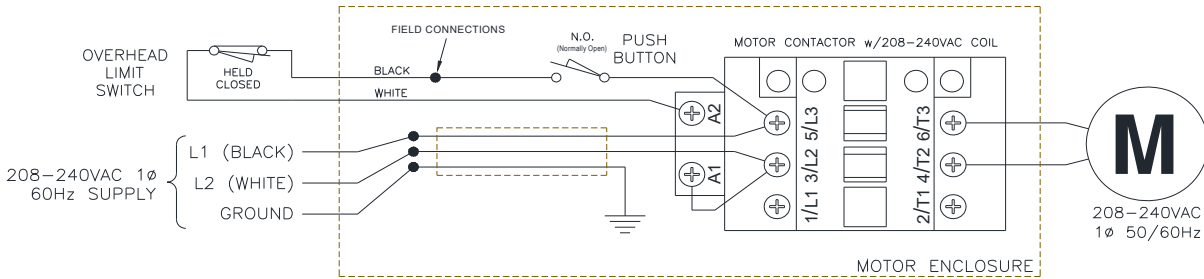

FOR THREE PHASE

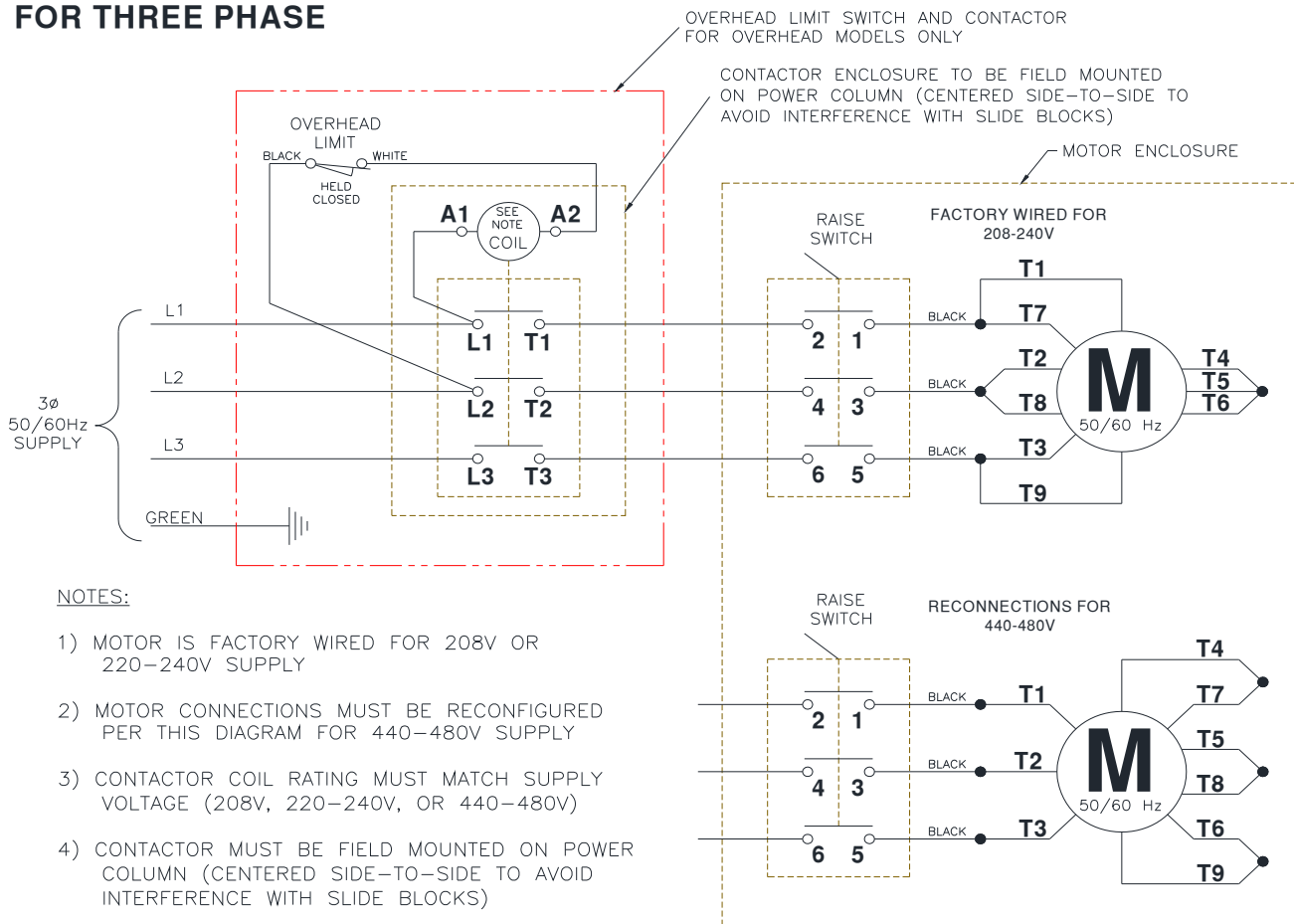

Fig 13 –Electrical Wiring Diagram

OPERATION PROCEDURE

SAFETY NOTICES AND DECALS

This product is furnished with graphic safety warning labels, which are reproduced on page 3 of these instructions. Do not remove or deface these warning labels or allow them to be removed or defaced. For your safety, and the safety of others, read and understand all of the safety notices and decals included.

OWNER/EMPLOYER RESPONSIBILITIES

This lift has been designed and constructed according to ANSI/ALI ALCTV standard. The standard applies to lift manufacturers, as well as to owners and employers. The owner/employer's responsibilities as prescribed by ANSI/ALI ALOIM, are summarized below. For exact wording refer to the actual standard provided with this manual in the literature pack.

The Owner/Employer shall ensure that lift operators are qualified and that they are trained in the safe use and operation of the lift using the manufacturer's operating instructions; ALI/SM, *ALI Lifting it Right safety manual*; ALI/ST, *ALI Safety Tips card*; ANSI/ALI ALOIM, *American National Standard for Automotive Lifts-Safety Requirements for Operation, Inspection and Maintenance*; ALI/WL Series, *ALI Uniform Warning Label Decals/Placards*; and in case of frame engaging lifts, ALI/LP-GUIDE, *Vehicle Lifting Points/Quick Reference Guide for Frame Engaging Lifts*.

The Owner/Employer shall establish procedures to periodically inspect the lift in accordance with the lift manufacturer's instructions or ANSI/ALI ALOIM, *American National Standard for Automotive Lifts-Safety Requirements for Operation, Inspection and Maintenance*; and the employer shall ensure that the lift inspectors are qualified and that they are adequately trained in the inspection of the lift.

The Owner/Employer shall establish procedures to periodically maintain the lift in accordance with the lift manufacturer's instructions or ANSI/ALI ALOIM, *American National Standard for Automotive Lifts-Safety Requirements for Operation, Inspection and Maintenance*; and the employer shall ensure that the lift maintenance personnel are qualified and that they are adequately trained in the maintenance of the lift.

The Owner/Employer shall maintain the periodic inspection and maintenance records recommended by the manufacturer or ANSI/ALI ALOIM, *American National Standard for Automotive Lifts-Safety Requirements for Operation, Inspection and Maintenance*.

The Owner/Employer shall display the lift manufacturer's operating instructions; ALI/SM, *ALI Lifting it Right safety manual*; ALI/ST, *ALI Safety Tips card*; ANSI/ALI ALOIM, *American*

National Standard for Automotive Lifts-Safety Requirements for Operation, Inspection and Maintenance; and in the case of frame engaging lift, ALI/LP-GUIDE, *Vehicle Lifting Points/Quick Reference Guide for Frame Engaging Lifts*; in a conspicuous location in the lift area convenient to the operator.

IMPORTANT SAFETY INSTRUCTIONS

When using your garage equipment, basic safety precautions should always be followed, including the following:

1. Read all instructions.
2. Care must be taken as burns can occur from touching hot parts.
3. To reduce the risk of fire, do not operate equipment in the vicinity of open containers of flammable liquids (gasoline).
4. Keep hair, loose clothing, fingers, and all parts of body away from moving parts.
5. Use only as described in this manual. Use only manufacturer's recommended attachments.
6. ALWAYS WEAR SAFETY GLASSES. Everyday eyeglasses only have impact resistant lenses, they are not safety glasses.

SAVE THESE INSTRUCTIONS

LIFTING A VEHICLE

- 1) Ensure that the lifting arms are parked, out to full drive thru position.
- 2) Position the vehicle in the service bay so that the vehicle's center of gravity is on a line between the two columns, and so the vehicle is centered between the two columns.

DO NOT EXCEED 3750 POUNDS PER ARM.

DO NOT ATTEMPT TO LIFT THE VEHICLE WITH ONLY TWO ARMS, AS THIS WILL VOID THE WARRANTY

ENSURE THAT THE HIGHEST POINT ON THE VEHICLE WILL CONTACT THE OVERHEAD LIMIT SWITCH BAR.

REFER TO THE VEHICLE MANUFACTURERS SERVICE MANUAL, TECHNICAL BULLETINS, "VEHICLE LIFTING POINTS GUIDE" (ALI/LP-GUIDE) OR OTHER PUBLICATIONS TO LOCATE THE RECOMMENDED LIFTING POINTS.

- 3) Position the arms and adapters so all four pads contact the vehicle simultaneously.

The vehicle should remain level during lifting.

- 4) Raise the lift until all four wheels are off the ground. Test the stability of the vehicle by attempting to rock the vehicle. Check adapters for secure contact with vehicle lift points. If the vehicle seems unstable, lower the lift and readjust the arms. If the vehicle is stable, raise the vehicle to a height a few inches above the desired working height.
- 5) Lower the vehicle until the locks on both columns engage. The vehicle should remain level when both locks are engaged. If one side engages and the other continues to descend, stop lowering the vehicle, raise it several inches, and try again to engage both locks.

Always lower lift into locks before entering the area beneath the vehicle.

Always use safety stands when removing or installing heavy components.

LOWERING A VEHICLE

- 1) Ensure that the area under the vehicle is clear of personnel and tools.
- 2) Raise the vehicle until both locks are free.
- 3) Disengage the locks by pulling and holding the lock release lever.
- 4) Lower the vehicle by depressing the lowering valve handle.
- 5) Continue to lower the vehicle until the carriages stop against the base plate. Retract the extension arms and park them.

LOSS OF POWER

If for any reason the lift will not rise off the locks or the locks will not retract, consult factory authorized personnel.

DO NOT OVERRIDE ANY SAFETY FEATURE IN AN ATTEMPT TO LOWER THE LIFT.

MAINTENANCE

To avoid personal injury, permit only qualified personnel to perform maintenance on this equipment. Maintenance personnel should follow lockout/tagout instructions per ANSI Z244.1.

The following maintenance points are suggested as the basis of a routine maintenance program. The actual maintenance program should be tailored to the installation and include a record of each planned maintenance activity and repair maintenance activity performed. Refer to the maintenance section of the ANSI/ALI ALOIM booklet (blue book) provided with the lift.

- If lift stops short of full rise or chatters, check fluid level and bleed both cylinders per Installation Instructions.
- Replace all Safety, Warning or Caution Labels if missing or damaged (**See Installation instructions page 3.**)

Daily

- Keep lift components clean.
- Check for loose or broken parts.
- Check hydraulic system for fluid leaks.
- Check arm stop hardware and engagement by fully extending each arm. If arm stop hardware is loose, tighten hardware until spring lock washer is fully compressed.
- Check adapters for damage or excessive wear. Replace as required with genuine Snap-On Equipment parts.
- Check lock release activation. When properly adjusted, the idler column lock should rest firmly against the back of the column when engaged and pull clear of the column back when disengaged.

Weekly

- Check synchronizer cables and sheaves for wear. Replace as required with genuine Snap-On Equipment parts.
- Check lock release cable adjustment per Installation Instructions step 49.

IMPORTANT: IF IDLER SIDE LOCK PAWL DOES NOT FULLY DISENGAGE, DAMAGE MAY RESULT TO IDLER SIDE CARRIAGE AND OR CABLE SYNCHRONIZING SYSTEM.

- Check synchronizer cable tension per Installation Instructions. Adjust if necessary.

Monthly

- Torque concrete anchor bolts to 80 ft-lbs.
- Check overhead shutoff switch. While raising lift, operate overhead shutoff bar. Power Unit motor should stop when bar is raised.
- Lubricate carriage slide tracks with heavy viscous grease. (Grease all (4) corners of both columns.)
- Visually inspect concrete floor for cracks and/or spalls within 12" of base plate

If any problems are encountered, contact your local service representative.

Model E15
Installation, Operation and Maintenance
PARTS BREAKDOWN

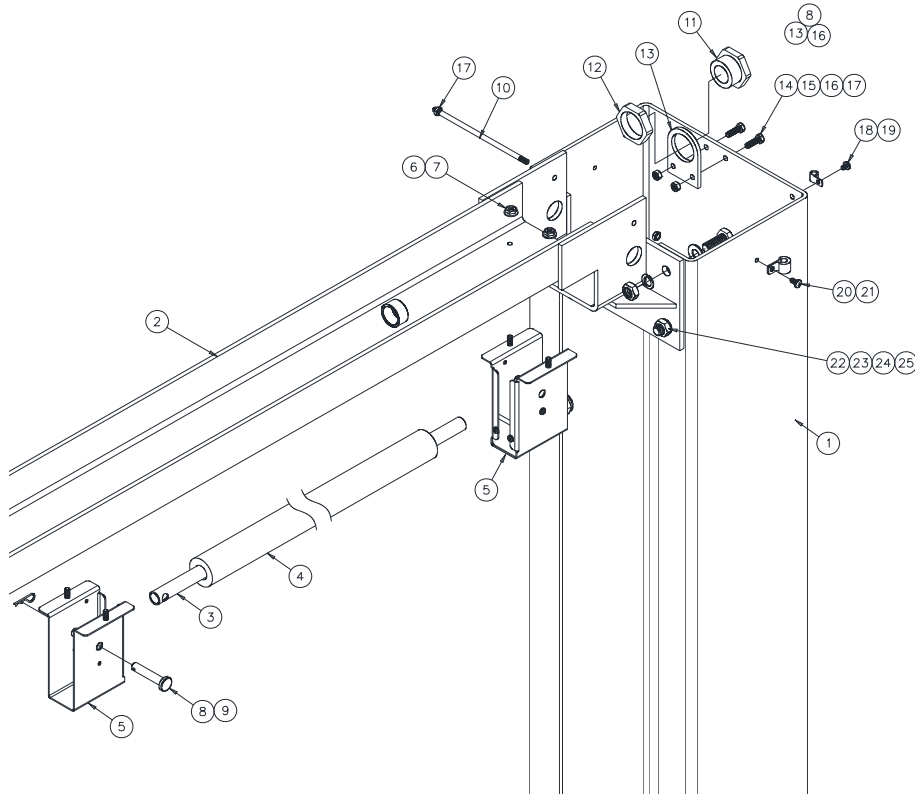

ITEM #	PART #	QTY/LIFT	DESCRIPTION
1	E15-01-02-01	2	COLUMN EXTENSION
2	E15-03-01-00	1	OVERHEAD WELD
3	A2067	1	OVERHEAD SHUT OFF BAR
4	31129	1	OVERHEAD SHUT OFF BAR CUSHION
5	B2064-01	1	LIMIT SWITCH PACKAGE (INCLUDES SWITCH w/ CORD, BOTH BRACKETS, & ITEMS 6-9)
6	B2065-3	4	M6 x 14mm PHILLIPS PAN HEAD SCREW
7	B2065-4	4	M6 SERRATED FLANGE HEX NUT
8	B2065-5	1	CLEVIS PIN 10mm x 55 Lg.
9	GJY12-3	1	HAIRPIN COTTER
10	E15-03-07	2	CABLE TRAPPING ROD
11	JSJ4-02-17	2	HOSE GUIDE
12	JSJ4-02-18	2	HOSE GUIDE NUT
13	E15-01-10	2	HOSE GUIDE BRACKET
14	X10-051	4	M6 x 20mm BOLT
15	X10-033	4	M6 LOCK WASHER
16	X10-032	4	M6 WASHER
17	X10-034	8	M6 NUT
18	1-05082A	2	6mm HOSE CLAMP
19	X10-065	2	M5 x 10mm PAN HEAD SCREW
20	1-03382A	5	16mm HOSE CLAMP
21	VS10-10-25	5	M8 x 12mm PAN HEAD SCREW
22	X10-037	8	M12 x 30mm BOLT
23	X10-038	8	M12 WASHER
24	X10-039	8	M12 LOCK WASHER
25	X10-040	8	M12 HEX NUT

IMPORTANT

Replace all worn, damaged, or broken parts with parts approved by **Challenger Lifts Inc.**
or with parts meeting **Challenger Lifts Inc.** specifications.
Contact your local Challenger Lifts Parts Distributor for pricing and availability.
(Call **Challenger Lifts Inc.** (502) 625-0700 for the Parts Distributor in your area)

Model E15
Installation, Operation and Maintenance

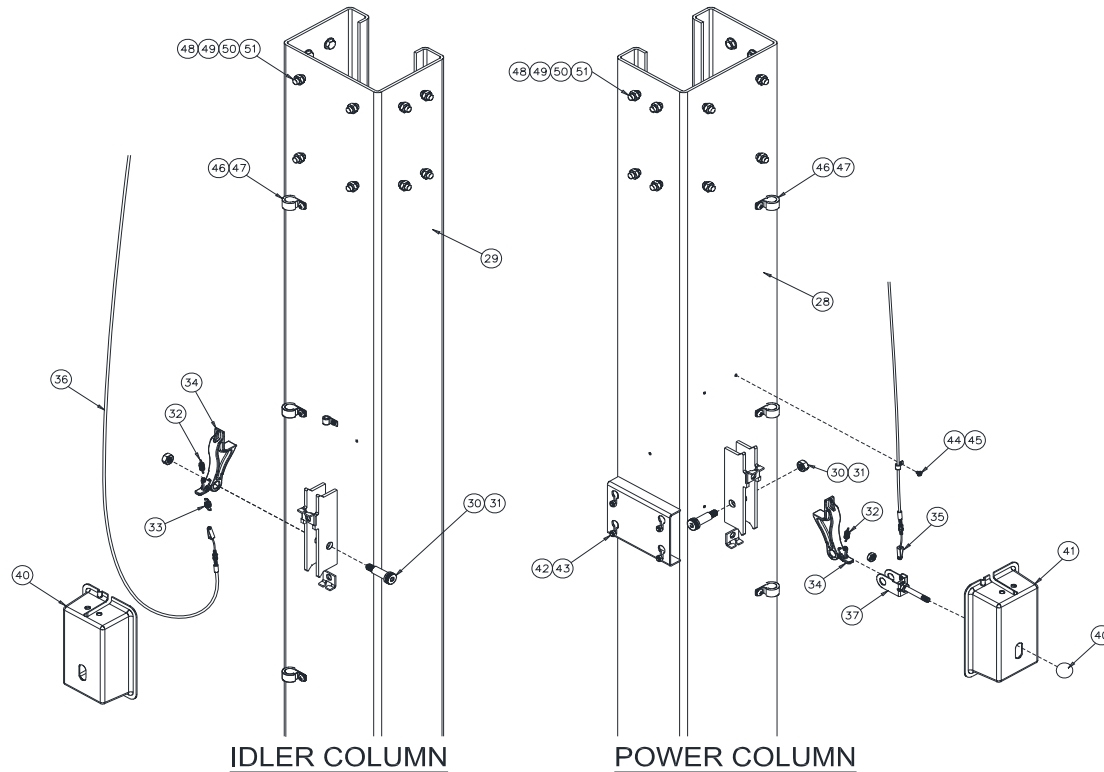

ITEM #	PART #	QTY/LIFT	DESCRIPTION
28	E15-01-01-00	1	POWER COLUMN WELD
29	E15-02-01-00	1	IDLER COLUMN WELD
30	30020	2	SHOULDER BOLT
31	37013	2	M12 LOCK NUT
32	JSJ5-02-07CH	2	LOCK SPRING, 3/8" O.D.
33	JSJ5-02-08CH	1	LOCK SPRING, 1/2" O.D.
34	E15-01-08	2	LOCK PAWL
35	37119	1	CLEAVIS PIN KIT
36	E15-06-00	1	LOCK RELEASE CABLE ASSEMBLY
37	JSJ5-02-04-00CH	1	LOCK ASSEMBLY (LOCK RELEASE CLEAVIS, HANDLE STUD, M10 LOCK NUTS)
40	JSJ3-01-02-2-9	1	LOCK KNOB
41	JSJ5-02-14CH	2	LOCK COVER
42	X10-060	4	M8 x 25mm BOLT
43	X10-048	4	M8 NUT
44	1-05082A	2	5mm HOSE CLAMP
45	X10-065	2	M5 x 10mm PAN HEAD SCREW
46	1-03382A	7	16mm HOSE CLAMP
47	VS10-10-25	7	M8 x 12mm PAN HEAD SCREW
48	X10-037	24	M12 x 30mm BOLT
49	X10-038	24	M12 WASHER
50	X10-039	24	M12 LOCK WASHER
51	X10-040	24	M12 NUT

IMPORTANT

Replace all worn, damaged, or broken parts with parts approved by **Challenger Lifts Inc.** or with parts meeting **Challenger Lifts Inc.** specifications.

Contact your local Challenger Lifts Parts Distributor for pricing and availability.
(Call **Challenger Lifts Inc.** (502) 625-0700 for the Parts Distributor in your area)

Model E15
Installation, Operation and Maintenance

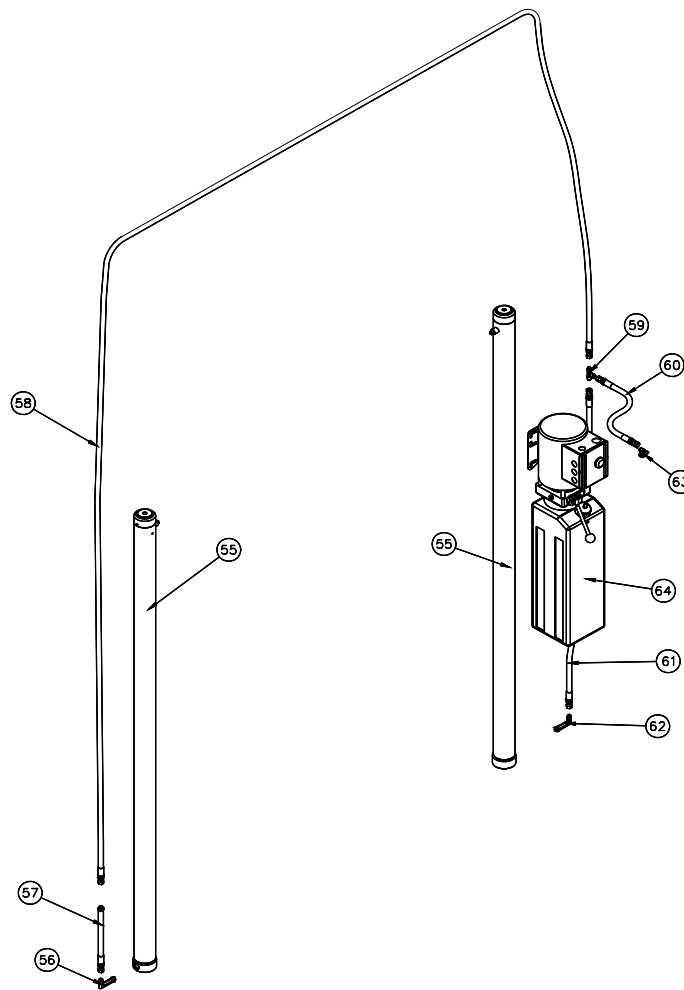

ITEM #	PART #	QTY/LIFT	DESCRIPTION
55	E15-07-00	2	HYDRAULIC CYLINDER
56	JSJ6-21	1	5/8-18 UN 90 DEGREE ELBOW
57	E15-20	1	5/8-18 UN HOSE EXTENSION (2' Ext. Height)
58	E15-18	1	5/8-18 UN HOSE
59	JSJ6-15	1	9/16-18 UN x 9/16-18 UN x 5/8-18 UN TEE FITTING
60	E15-17	1	9/16-18 UN POWER UNIT HOSE
61	JSJ4-16	1	9/16-18 UN POWER CYLINDER HOSE
62	JSJ6-19	1	9/16-18 UN 90 DEGREE ELBOW
63	JSJ5-19	1	O-RING x 9/16-18 UN 90 DEGREE ELBOW
64	AB-9367-DLH	1	POWER UNIT 1PH 230V 50/60Hz
	AD-9367		POWER UNIT 3PH 208/230/460V 50/60Hz

IMPORTANT

Replace all worn, damaged, or broken parts with parts approved by **Challenger Lifts Inc.**
or with parts meeting **Challenger Lifts Inc.** specifications.

Contact your local Challenger Lifts Parts Distributor for pricing and availability.
(Call **Challenger Lifts Inc.** (502) 625-0700 for the Parts Distributor in your area)

Model E15
Installation, Operation and Maintenance

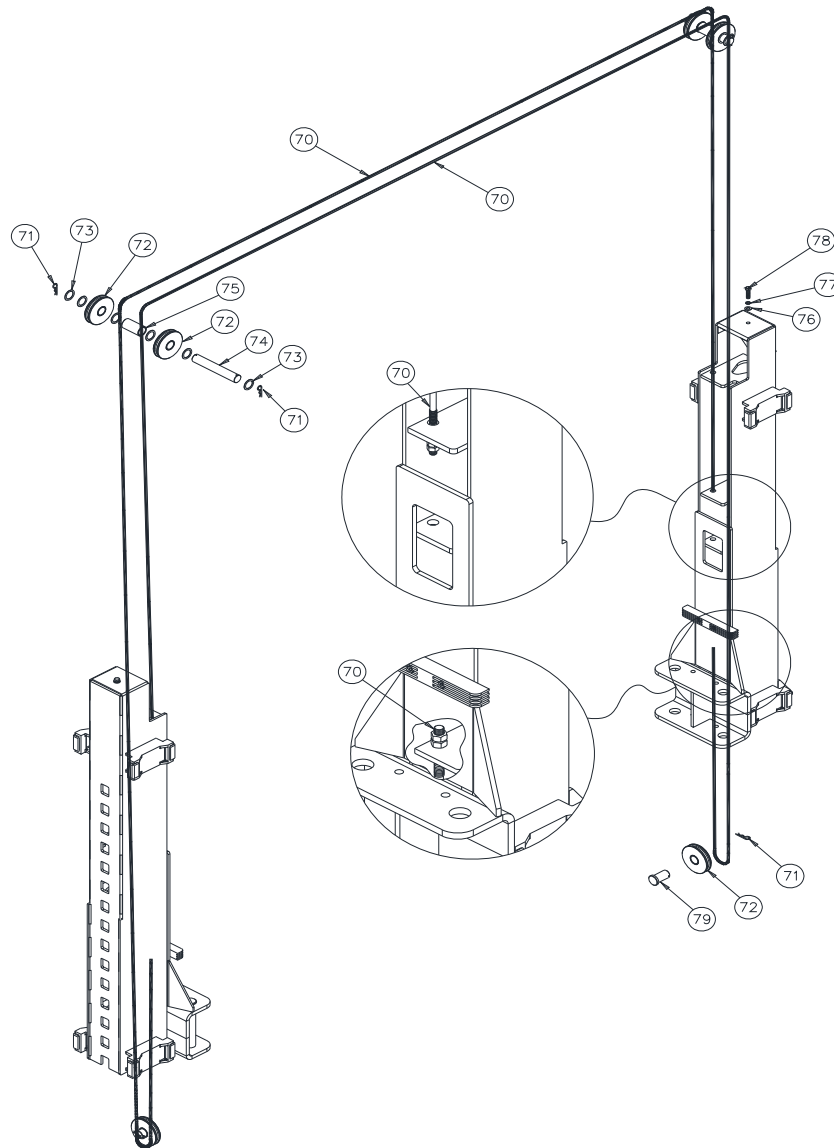

ITEM #	PART #	QTY/LIFT	DESCRIPTION
70	E15-04-00	2	SYNCHRONIZER CABLE
71	E15-03-09	6	HAIRPIN COTTER PIN
72	E15-03-08-00	6	CABLE SHEAVE
73	E15-03-06	12	35mm ID x 48mm OD WASHER
74	E15-03-03	2	CABLE SHEAVE PIN
75	E15-03-05	2	SHEAVE SPACER
76	X10-038	2	M12 WASHER
77	X10-039	2	M12 LOCK WASHER
78	X10-053	2	M12 x 45mm BOLT
79	E15-01-09	2	LOWER SHEAVE PIN

IMPORTANT

Replace all worn, damaged, or broken parts with parts approved by **Challenger Lifts Inc.** or with parts meeting **Challenger Lifts Inc.** specifications.

Contact your local Challenger Lifts Parts Distributor for pricing and availability.
(Call **Challenger Lifts Inc.** (502) 625-0700 for the Parts Distributor in your area)

Model E15
Installation, Operation and Maintenance

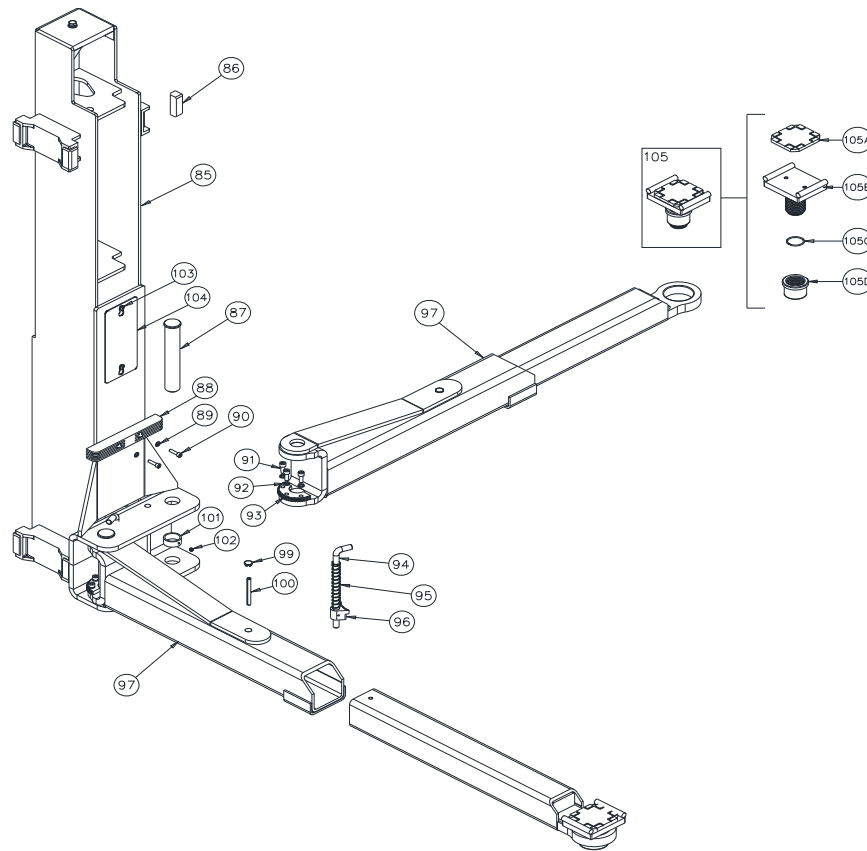

ITEM #	PART #	QTY/LIFT	DESCRIPTION
85	E15-08-01-00	2	CARRIAGE
86	JSJ5-08-15	16	SLIDE BLOCKS
87	JSJ6-11	4	ARM PIN
88	JSJ4-05-CH	2	DOOR GUARD
89	X10-087	4	M8 WASHER
90	X10-088	4	M8 x 30mm Lg. SOCKET HEAD BOLT
91	X10-077	12	M10 x 25mm Lg. SOCKET HEAD BOLT
92	X10-074	12	M10 LOCK WASHER
93	JSJ6-09-07	4	INNER GEAR
94	E15-13	4	ARM RESTRAINT SHAFT
95	JSJ6-14	4	ARM RESTRAINT SPRING
96	JSJ6-12	4	OUTER GEAR
97	E15-09-00	4	ARM ASSEMBLY
99	111529	4	18 MM DIA. PLASTIC PLUG
100	GB879.1-2000	4	M10 x 100 LG SPRING PIN
101	JSJ5-22CH	4	40.5 x 48 x 20mm Lg. Collar
102	JSJ5-23CH	4	M8 x 8mm SET SCREW CUP POINT
103	VS10-10-25	4	M8 x 12mm Lg. PPHS
104	E15-08-02	2	CARRIAGE COVER
105	B12162S	4	FOOT PAD ASSEMBLY
105A	A1104-H	4	PAD
105B	B12163S	4	ADAPTER PAD WELD
105C	B17257	4	3 x 45mm RETAINING RING
105D	B12067	4	ADAPTER BASE

Replace all worn, damaged, or broken parts with parts approved by **Challenger Lifts Inc.** or with parts meeting **Challenger Lifts Inc.** specifications.
Contact your local Challenger Lifts Parts Distributor for pricing and availability.
(Call **Challenger Lifts Inc.** (502) 625-0700 for the Parts Distributor in your area)

Model E15
Installation, Operation and Maintenance

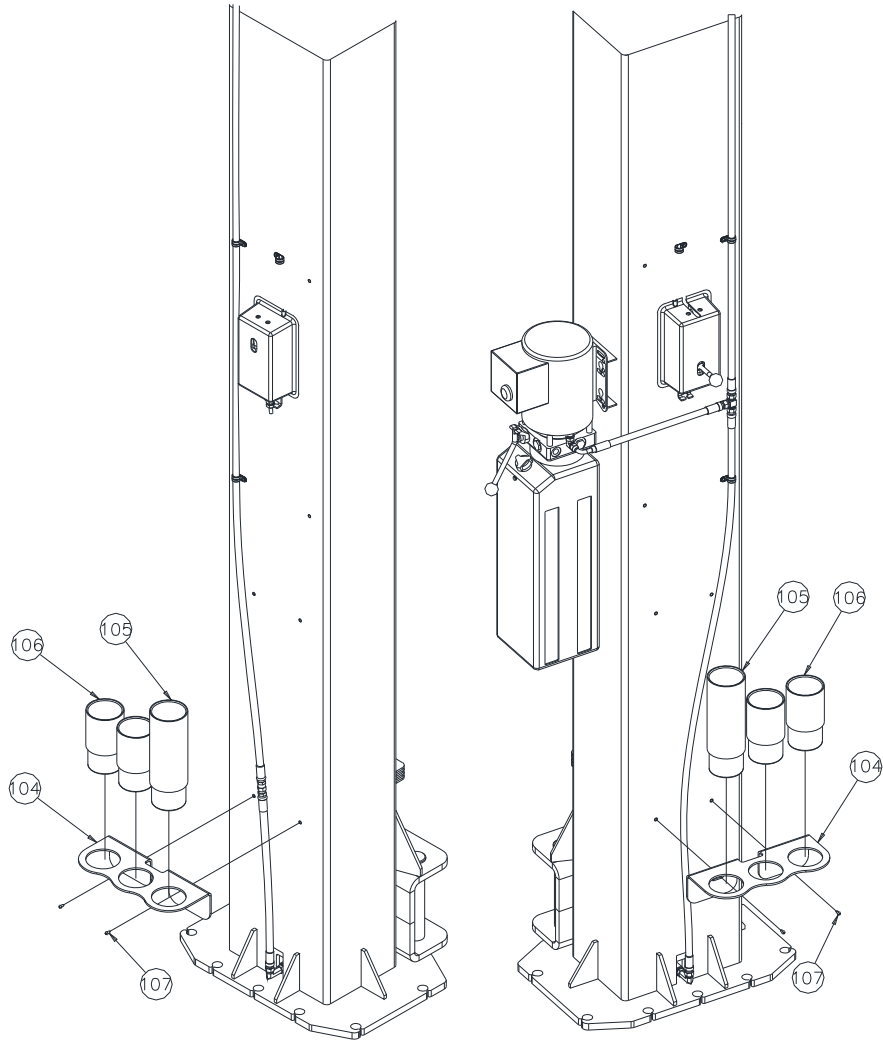

ITEM #	PART #	QTY/LIFT	DESCRIPTION
104	12091	2	ADAPTER RACK
105	B12068	2	ADAPTER EXTENSION LONG (8")
106	B12069	4	ADAPTER EXTENSION SHORT (4")
107	10335	4	5/16-18NC x 3/8" Lg. PHILLIPS PAN HEAD SCREW

Replace all worn, damaged, or broken parts with parts approved by **Challenger Lifts Inc.** or with parts meeting **Challenger Lifts Inc.** specifications.
 Contact your local Challenger Lifts Parts Distributor for pricing and availability.
 (Call **Challenger Lifts Inc.** (502) 625-0700 for the Parts Distributor in your area)

REVISIONS

2020/02/13 – 12073 WAS CHANGED TO 10335

2023/11/15 – UPDATED ANSI/ALI REFERENCE MATERIAL. UPDATED AMCHORING INSTRUCTIONS Pg. 5.

2024/03/18 – ADDED ANSI STANDARDS REFERENCE STATEMENT SECTION. PG. 4

2024/09/30 – UPDATED ANSI/ALI STATEMENT

2026/06/16 – UPDATED POWER UNITS TO INCLUDE 3PH OPTION.