





## 15K 4-POST 4115 OPEN OR CLOSED FRONT

The 26" wide runways allow you to service or align a wide range of vehicles like small passenger cars, medium-duty trucks, and medium-sized vans, up to 15,000 lbs. Align vehicles from 183" to 210" in wheelbase length.

-  **78" + VEHICLE**
-  **14' RECOMMENDED**
-  **24' RECOMMENDED**
-  **208-230V, 1PH, 30A**
-  **90-120 PSI**

OPEN FRONT

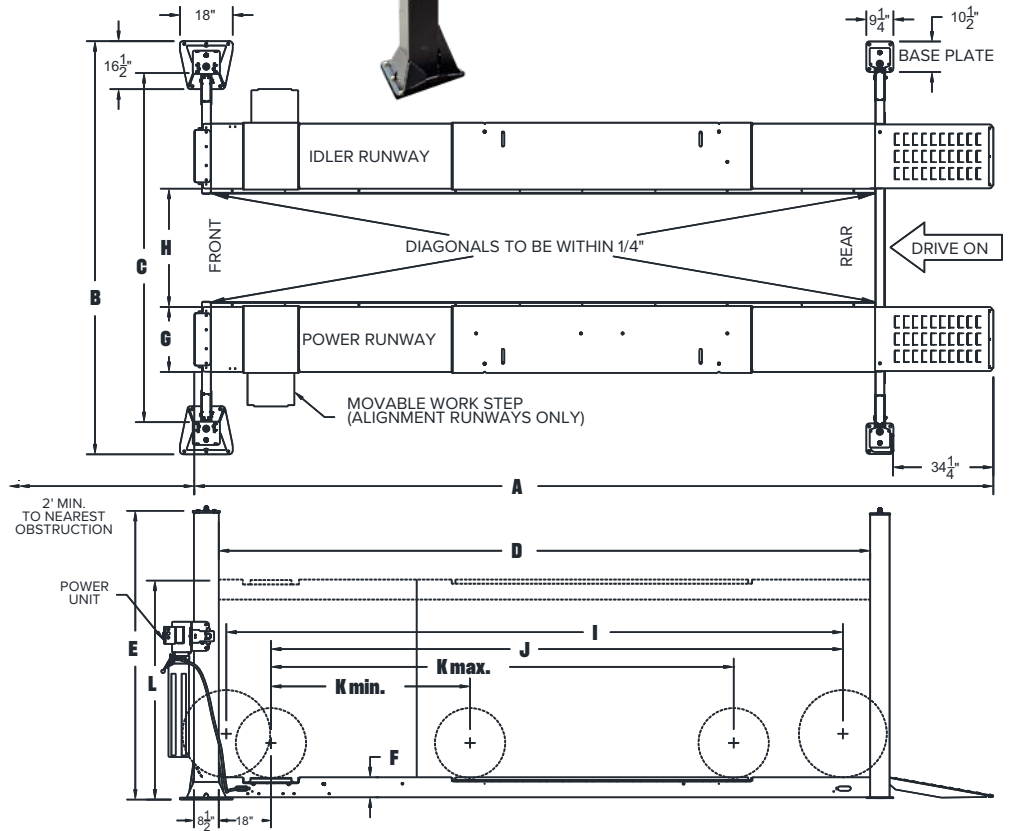

MODEL NUMBER	4115EFO	4115XFO	4115EFX	4115XFX	AR4115EAO	AR4115XAO	AR4115EAX	AR4115XAX
Description	Standard, Open-Front, Flat Deck	Extended Length, Open-Front, Flat Deck	Standard, Closed-Front, Flat Deck	Extended Length, Closed-Front, Flat Deck	Standard, Open-Front, Alignment Deck	Extended Length, Open-Front, Alignment Deck	Standard, Closed-Front, Alignment Deck	Extended, Closed-Front, Alignment Deck
Lifting Capacity	<b>15,000 lbs.</b>							
Open or Closed Front	Open		Closed		Open		Closed	
Max. Wheelbase (I)	183"	210½"	183"	210½"	183"	210½"	183"	210½"
Max. 2-Wheel Alignment (J)			NA		167¾"	195¼"	167¾"	195¼"
Max. 4-Wheel Alignment (K)			NA		68" - 158"			
Rise Height (L)	78"							
Overall Length (A)	20' 10¾"	23' 1"	20' 7⅝"	22' 11½"	20' 10¾"	23' 1"	20' 7⅝"	22' 11½"
Overall Width (B)	Front: 142" Rear: 141¾"		141¾"		Front: 142" Rear: 141¾"		141¾"	
Inside Columns (C)	Front: 120¾" Rear: 125½"		125½"		Front: 120¾" Rear: 125½"		125½"	
Between Columns (D)	195"	222½"	196¾"	223¾"	195"	222½"	196¾"	223¾"
Height of Columns (E)	Front: 99¼" Rear: 98"		98"		Front: 99¼" Rear: 98"		98"	
Width of Runways (G)	26"							
Height of Runways (F)	7"							
Width Between Runways	40¾"							
Air Supply Required	90-120 psi							
Standard Motor/Voltage*	3HP, 208v-230v, 60Hz, 1Ph							
Rise Time	85s							
Required Bay Size W x L	14' x 24'	14' x 26'	14' x 24'	14' x 26'	14' x 24'	14' x 26'	14' x 24'	14' x 26'
ALI* Certified	☑							

